

SDC-BT diode driver

User manual

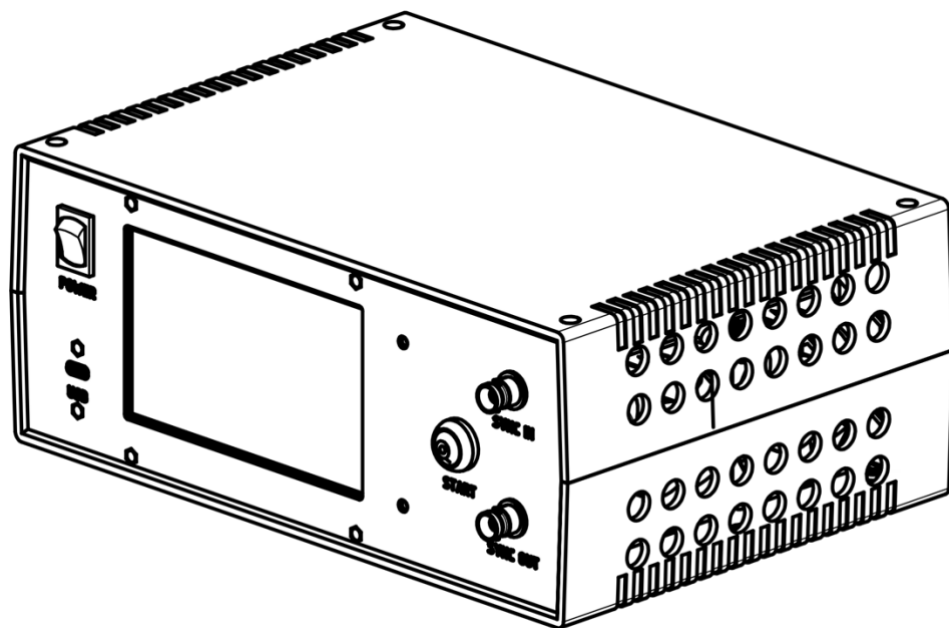

Warning! This equipment can be dangerous.
Please read this entire user manual carefully before operating the product.

Table of contents

Table of contents	2
Overview / Appearance	3
Cooling	4
Contents of delivery	4
Front panel description	5
Back panel description	6
Safety	9
Installation	9
Operations (stand-alone regime of operations)	9
Faults	10
Technical notes	11
Specifications	12
Dimensional drawing.....	14
How to order?	15
Appendix 1: Software description	19
Appendix 2: RS-232 / RS-485 communication protocol, its description.....	28
Appendix 3: Demo PC software, its description	28
Appendix 4: Embedded version	29

Overview / Appearance

SDC-BT is a family of laser diode drivers designed for pumping medium-power Nd:YAG-like solid-state lasers. The driver has an embedded current source, buffer capacitor bank, capacitor charger, one or two TEC modules (see also the full driver's architecture in the picture on the next page). It is also capable of powering and controlling a Pockels cell driver for generation of Q-switched pulses. The SDC-BT is able to send adjustable output synchronization signals to other equipment.



Main features of the SDC-BT drivers (may vary by part number):

- Wide-range 110-240VAC input.
- Output current – several models, up to 400A.
- Output voltage – several models, up to 450V (*).
- Pulse widths are typical for Nd:YAG pumping (50-300us, wider on request), rise time is fast (20-30us typically), and adjustable (soft-start ramp to current setpoint).
- Maximum average output power is 100W.
- 1x high-power TEC onboard – 10A/20V/200W max.
- 1x low-power TEC onboard – 5A/20V/50W max.
- Control of an external Pockels cell driver (purchased separately and connected to the SDC-BT driver from outside), synchronization features.

(*). See [How to order?](#) section for details.

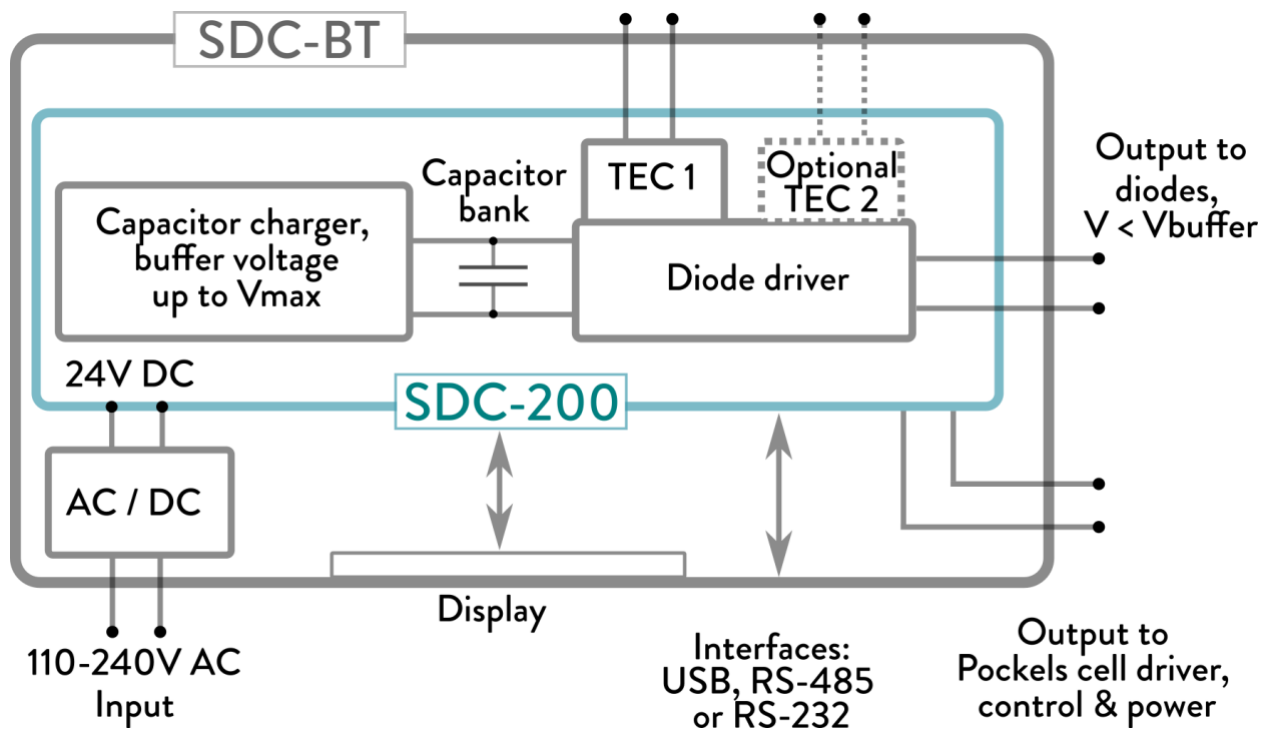

All the important parameters for SDC-BT laser diode driver (such as output current, buffer voltage, pulse width, pulse repetition rate and others) can be configured via the front panel user interface (5" color touchscreen display) or can be controlled from a computer via the USB or via the RS-485 interface. The default interface is the RS-485 (the RS-232 is available upon request).

Cooling

The driver is cooled by built-in fans. External cooling is not required.

Contents of delivery

By default, the delivery package contains the following parts:

- SDC-BT diode driver – 1pc
- Power cord (European plug) – 1pc
- DIODE mating cable (100cm length) – 1pc
- TEC mating cable (100cm length) – 1-2pcs (depends on model)
- INTERFACE mating cable (100cm length) – 1pc
- PCD mating cable (to a Pockels cell driver, 100cm length) – 1pc
- Stylus pen and stylus holder – 1set
- USB flash drive with PC software – 1pc

Front panel description



ELEMENT	DESCRIPTION
POWER switch	Power switch, turns the driver on and off.
START button	Starts and stops current pulses delivered to the DIODE output.
START LED	The corresponding LED indicates the state of START button.
SYNC IN	Syncro input (1kOhm input impedance, amplitude 5V TTL, pulse width >1us).
SYNC OUT	Syncro output (50 Ohm impedance, amplitude 5V, duration 5us). Sync out pulses are shifted relatively to the trailing edge of the TTL pulse applied to the diode driver of SDC-BT by the specified SYNC DELAY value. SYNC DELAY can be positive or negative.
USB	PC connection.
Stylus pen / stylus holder	The user can install or remove the stylus holder themselves.

Back panel description

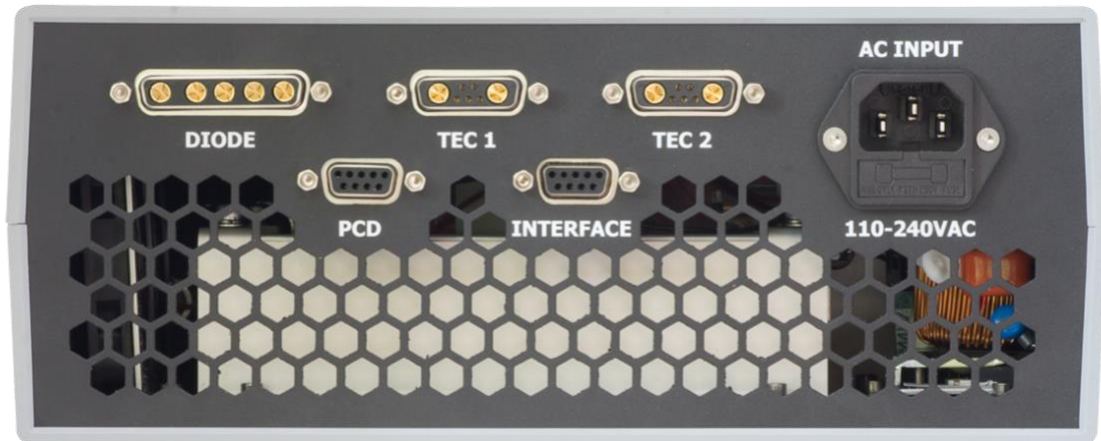

AC INPUT

AC power input, 110-240VAC, 50/60Hz, 1ph.
The socket also contains a 5A fuse holder.

DIODE

Diode connection (5 pin mixed D-SUB connector of 5W5 type, receptacle).

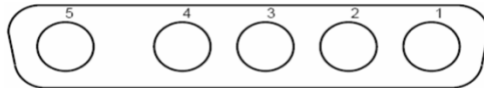

PIN	DESIGNATION	DESCRIPTION
2 (red)	DIODE “+”	Diode’s anode
4 (black)	DIODE “-”	Diode’s cathode

Important note

Since the diode driver has no galvanic insulation between input and output, the diode’s anode is under buffer voltage potential and the diode’s cathode is under floating potential different from the ground potential.

Therefore, both the diode’s anode and cathode cannot be grounded in any way and should be isolated from the ground.

Note: For better performance, we recommend keeping the inductance of the output cables as low as possible (the recommended value is <500nH).

TEC 1

Peltier connection (9 pin mixed D-SUB connector of 7W2 type, receptacle).
High power, 200W/10A/20V max.

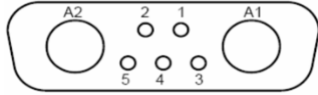

PIN	DESIGNATION	DESCRIPTION
A1 (red)	TEC +	Peltier red
A2 (black)	TEC -	Peltier black
1, 2 (blue)	NTC	NTC 10kOhm connection

TEC 2

Peltier connection (9 pin mixed D-SUB connector of 7W2 type, receptacle).
Low power, 50W/5A/20V max.

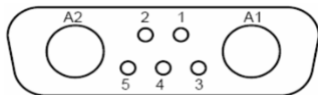

PIN	DESIGNATION	DESCRIPTION
A1 (red)	TEC +	Peltier red
A2 (black)	TEC -	Peltier black
1, 2 (blue)	NTC	NTC 10kOhm connection

Note: Some modifications are supplied with TEC 1 only,
see also [How to order?](#) section.

PCD

Pockels cell driver connection (standard 9 pin D-SUB connector, receptacle). Recommended drivers are [QBD-series](#) and [QBU-series](#) offered by OEM Tech.

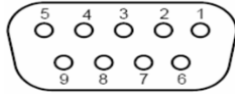

PIN (COLOR)	DESIGNATION	DESCRIPTION
1, 6, 7, 8 (-)	N/C	-
2 (red)	+24VDC	Power to the Pockels cell driver.
3 (blue)	Q-switch	Q-switch/Pulse signal to the Pockels cell driver. The signal can be configured to match the requirements of QBD-series and QBU-series drivers.
4 (green)	PCD Enable	Enable signal to the Pockels cell driver.
5 (yellow)	HV Program	HV Program signal to the Pockels cell driver.
9 (black)	GND	Return of PCD circuits.

INTERFACE

IDC and RS485 interface (standard 9 pin D-SUB connector, receptacle).

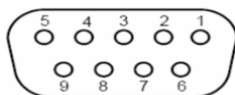

PIN (COLOR)	DESIGNATION	DESCRIPTION
1 (orange)	IDC	IDC (Interlock door connector).
2 (black)	IDC return	Blocks the operations if the circuit is open.
3 (violet)	RS-485 B	RS-485 interface of SDC-BT.
7 (green)	RS-485 A	RS-485 and USB circuits are galvanically isolated from other circuits, but not from each other.

GROUNDING

Grounding policy

Most of the SDC-BT circuits (DIODE, TEC 1, TEC 2) have common ground. PCD, SYNC IN, SYNC OUT, and IDC are galvanically isolated from each other and other circuits. RS-485 and USB are galvanically isolated from other circuits, but not from each other.

Safety

Warning! This equipment produces high voltages that can be very dangerous. Be careful in a high-voltage appliances area.

- Assemble the entire setup before powering the device.
- Do not remove the coverage case from the driver.
- Do not repair the driver yourself, there are no user-serviceable parts inside.
- Do not operate the device with load disconnected.
- Avoid casual contacts of personnel with output cables and with the load.
- Do not connect or disconnect cables while the driver is powered on.
- Do not turn on the driver if it has been damaged by water, chemicals, mechanical or electrical shock.

Installation

- Disconnect the driver from AC mains.
- Connect your diode to the driver's DIODE connector.
- **Ensure that neither the diode's positive (anode) nor the diode's negative (cathode) is grounded in any way.**
- If necessary, connect your Peltier and a NTC thermistor to the driver's TEC 1 connector. Make sure the NTC thermistor has good thermal contact with the diode heatsink. If required, an additional Peltier element and NTC thermistor can be connected to the TEC 2 connector.
- If necessary, connect your Pockels cell driver to the driver's PCD connector.
- Organize your IDC connection (INTERFACE connector of the driver). Ensure that IDC circuit is "closed" when you start the operations.
- If connection to PC is required, connect the driver to the PC via USB connector. Install the Windows software from the USB flash drive supplied together with the SDC-BT driver.
- If synchronization is required, connect the SDC-BT with other equipment using the SYNC IN and SYNC OUT connectors and BNC cables.
- Connect the driver to the mains using power plug provided. Ensure that your wall socket provides appropriate grounding.

Operations (stand-alone regime of operations)

- Assemble your setup following the [Installation](#) section, now your driver is connected to the mains.

- Since we consider here the operations in a stand-alone mode, neither PC nor other controlling device should be connected to driver's USB or RS-485 interfaces.
- Turn on the POWER switch.
- Wait until the driver's software loads and appears on its display.
- Select internal mode of the synchronization for the beginning.
- Select the most essential operating parameters (pulse current, buffer voltage, pulse width, pulse repetition rate). If possible, start with small pulse current, pulse width, pulse repetition rate. Set the buffer voltage to ~10V higher than the diode voltage stated in its datasheet.
- Enable the applicable circuits by switching slide buttons on the display one by one: the buffer voltage power source, TEC 1, TEC 2, and PCD.
- Press the START button on the driver's front panel. The driver will now begin operating. This will be indicated by the button LED.
- Check the current status indicator on the **Main screen** or **Diode control screen** of the SDC-BT. If the indicator is blue or red, adjust the buffer voltage on the **Diode control screen** ([link to the description](#)) until the indicator becomes green.
- Press the START button again to stop the operation.
- Turn off the POWER switch.

Faults

The driver raises faults in the cases listed below.
Some of them stop the operations, but some do not.

#	FAULT	DESCRIPTION / COMMENTS
1	OVERHEAT1	SDC-BT overheating (primary). This causes the diode driver to stop.
3	VOLTLOW	Buffer voltage is too low. The set buffer voltage is not sufficient to generate a current pulse of the specified value. This doesn't cause the diode driver to stop.
4	VOLTHIGH	Buffer voltage is too high. The set buffer voltage is much higher than required to generate a current pulse of the specified value, which causes overload of the internal components. The output pulse duration will be forcibly cut down to 70us. This doesn't cause the diode driver to stop.
7	TEC1	TEC 1 temperature is out of the allowed limits. This doesn't cause the diode driver to stop unless TEC stabilization is required to run diode driver.
8	TEC2	TEC 2 temperature is out of the allowed limits. This doesn't cause the diode driver to stop unless TEC stabilization is required to run diode driver.
9	OVERHEAT2	SDC-BT overheating (secondary). This causes the diode driver to stop.
11	IDC	Interlock is open. This causes the diode driver to stop.
12	DCDC	Buffer voltage power source failure. This causes the diode driver to stop.

13	POWER	Expected averaged output power is out of the allowed limits. This causes the diode driver to stop.
14	TECNR	TEC Not Ready – TEC 1 and/or TEC 2 is not stabilized. This is considered as a fault only if the corresponding TEC stabilization is required to run diode driver. In this case the diode driver will be stopped.

Technical notes

OUTPUT CABLES

The output cables inductance affects the SDC-BT performance. The higher inductance is, the higher current overshoot is. For better performance, we recommend keeping inductance of the output cables below 500nH. The recommended length of the output cables is 50cm or shorter.

However, the SDC-BT allows to adjust the rise time to suppress current overshoot when the longer output cables are used.

OUTPUT MEASUREMENT AND GROUNDING

Neither the DIODE “+” nor the DIODE “-” driver outputs may be grounded. Grounding either the DIODE “+” or DIODE “-” output may result in driver failure.

For the same reasons, do not connect an oscilloscope probe ground to DIODE “-” when measuring the output voltage. We recommend using differential probes for direct output voltage measurements.

Specifications

ELECTRICAL

Input:	
Input voltage	110-240VAC, 50/60Hz, 1ph
Current consumption	<5A @ 110VAC
Output:	
Regime of operations	Pulsed
Maximum buffer voltage (V_{MAX})	Model dependent (user selectable up to 450V), other on request
Maximum output voltage	Model dependent (see also How to order? section), other on request
Maximum output current (I_{MAX} or I_{250})	Model dependent (user selectable up to 400A), other on request I_{MAX} is fully achievable at pulse widths up to 250us, and is derated at longer pulses
Output current	Adjustable from approx. 10% of I_{MAX} to 100% of I_{MAX} , other on request
Buffer voltage	Adjustable in 10... V_{MAX} range, other on request
Pulse width	Adjustable in 50... T_{MAX} range, T_{MAX} is 300us by default, other on request
Pulse repetition rate	Adjustable up to 50-100Hz, other on request
Peak power	Model dependent (in ~20-50kW range), other on request
Maximum average output power	100W, other on request
Rise time	<20-30us typically, slow start adjustable in 0...50us range
Bias current	+, model dependent (~50-100mA)
TEC1:	
Current	Up to 10A
Voltage	Up to 20V
Power	200W max.
Feedback loop	10kOhm NTC
Temperature	+10 ... +40 °C by default, other on request
TEC2:	

Current	Up to 5A
Voltage	Up to 20V
Power	50W max.
Feedback loop	10kOhm NTC
Temperature	+10 ... +40 °C by default, other on request
Interfaces:	
UI	5" display with touchscreen
USB	+
RS-485 (RS-232 on request)	+
Protections:	
	Door-interlock connection, overheating, buffer voltage too low, buffer voltage too high, TEC1 out of range, TEC2 out of range, input frequency is too high
Cooling:	
	Forced-air cooling with built-in fans
Other:	
Synchro input	+
Synchro output	+
Pockels cell driver control	+ (The Pockels cell driver needs to be purchased separately, placed outside and connected with a cable)
Environmental:	
Operating temperature	+10 ... +40 °C
Storage temperature	-20 ... +60 °C
Humidity	<90%, non-condensing

MECHANICAL

Size (WxDxH)	260x180x104mm (see also the dimensional drawing below)
Weight	<3.0kg

Dimensional drawing

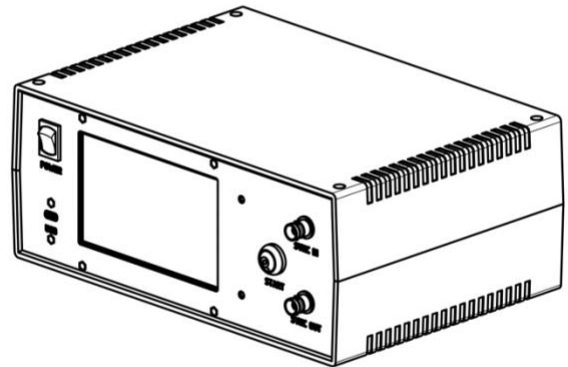
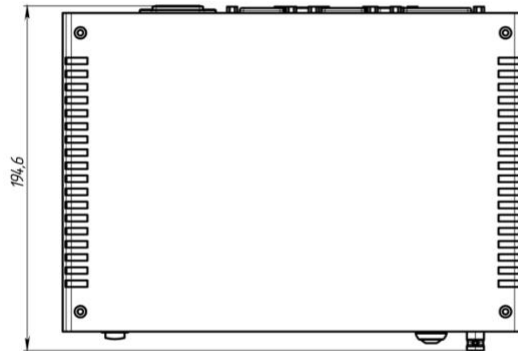
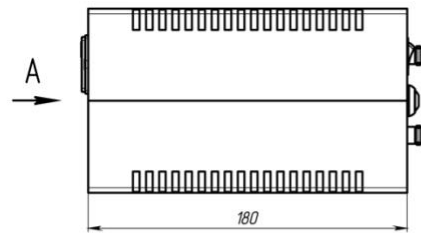
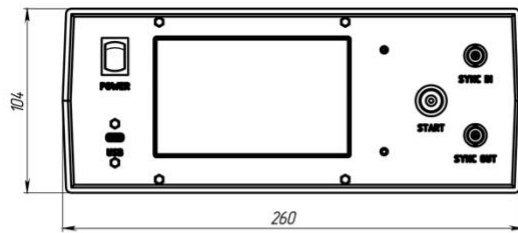

A

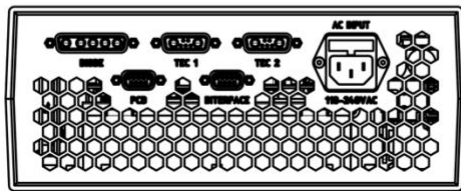

How to order?

SDC-BT-XXXX-[YYYY]-[VVVVV], where:

- XXXX codes the voltage version of the driver (nominal value, can be 63V, 80V, 100V, 126V, 160V, 200V, 250V, 400V, 450V, or custom). The maximum output current, internal capacitor bank capacitance, average output power, and number of TECs are fixed for each voltage version, see details in the table below.
- YYYY codes low-current and high-current versions of the driver. The low-current versions are optimized for low-current diodes and for operating regimes with low energy but high repetition rates. It is reasonable to choose a low-current version, which provides improved output-current quality in the low-current region, if the maximum operating current in your system is at least three times lower than the I_{MAX} of the standard model. If not specified, the standard version is supplied.
- VVVVV code defines the type of communication interface, it can be either RS232 or RS485. By default, the RS485 version is supplied.

LOW-VOLTAGE VERSIONS

Parameter	Value ⁽¹⁾			
Model P/N	SDC-BT-63V	SDC-BT-80V	SDC-BT-100V	SDC-BT-126V
Embedded capacitor bank:				
Voltage (V_{MAX})	63V	80V	100V	126V
Capacitance	10.8mF	10.8mF	6.0mF	3.6mF
Capacitor charging power supply:				
Buffer voltage	10V...63V	10V...80V	10V...100V	10V...126V
Maximum power in dependence on buffer voltage ⁽²⁾	>100W @ 30V...63V	>100W @ 30V...80V	>100W @ 30V...100V	>100W @ 30V...126V
Diode driver:				
Maximum output current:				
- @ 250us (I_{250})	350A	350A	300A	250A
- @ 300us (I_{300})	300A	300A	250A	200A
Minimum output current (I_{MIN})	10A	10A	10A	10A
Recommended diode voltage ⁽³⁾ :				
- @ I_{300} , 300us	<46V	<63V	<79V	<96V
- @ $\frac{1}{2} I_{250}$, 250us	<50V	<69V	<87V	<107V
Maximum pulse width (T_{MAX})	300us	300us	300us	300us
Minimum pulse width	50us	50us	50us	50us
Maximum repetition rate ⁽⁴⁾	100Hz	100Hz	100Hz	100Hz
Output limitations:				

Energy limit ⁽⁴⁾ ($I_{300} * V_{MAX} * T_{MAX}$)	~5.6J	~7.2J	~7.5J	~7.5J
Power limit	100W	100W	100W	100W
Guaranteed regimes	300A/46V/300us/15Hz 100A/25V/250us/100Hz	300A/63V/300us/10Hz 100A/25V/250us/100Hz	250A/79V/300us/10Hz 100A/25V/250us/100Hz	200A/96V/300us/10Hz 100A/25V/250us/100Hz
TEC 1	+	+	+	+
TEC 2	+	+	+	+
Low-current versions	SDC-BT-63V-100A	SDC-BT-80V-100A	on request	on request
I_{250} / I_{300}	100A / 100A	100A / 100A	–	–
I_{MIN}	5A	5A	–	–
High-current versions	SDC-BT-63V-400A	SDC-BT-80V-400A	on request	on request
Capacitance	14.4mF	14.4mF	–	–
I_{250} / I_{300}	400A / 350A	400A / 350A	–	–
I_{MIN}	10A	10A	–	–
Recommended diode voltage ⁽³⁾ : - @ I_{300} , 300us - @ $\frac{1}{2} I_{250}$, 250us	<44V <52V	<61V <69V	–	–
Guaranteed regimes	400A/44V/250us/10Hz 350A/44V/300us/10Hz	400A/44V/250us/10Hz 350A/44V/300us/10Hz	–	–

(1) Customizations (e.g. non-standard output currents, non-standard diode voltages and other parameters, software customizations, Pockels cell driver control customizations) are possible on request. Please contact the manufacturer for the details.

(2) In dependence on the topology of the internal DC/DC power converter the dependence of the output power of the capacitor charger from the output voltage is principally different for different models of SDC-BT. Low-voltage models deliver full output power in a wide range of the output voltages. Unlike them, high-voltage models are able to deliver full output power close to V_{MAX} only. At lower output voltages the output power of high-voltage models drops approximately linearly with the decreasing output voltage.

(3) Please note that the output voltage applied to the diodes is always lower than the buffer voltage due to voltage drops across internal components and wiring. The higher output current and pulse width are, the lower output voltage is possible with the same buffer voltage. On the contrary, the possible output voltage reaches exactly the buffer voltage at very low currents and pulse widths.

(4) If the diode voltage is close to V_{MAX} and the operating current is close to I_{MAX} , the typical pulse energy is ~5–7J, and 100Hz operation is not possible due to the 100W average power limitation. Therefore, 100Hz operation is only possible when the operating current and/or voltage are several times lower than I_{MAX} and V_{MAX} , respectively. In such cases, it may be reasonable to consider a low-current version of the driver.

Examples:

- SDC-BT-100V – fully standard 100V version with all the parameters as given above
- SDC-BT-63V-100A-RS232 – low-current version of 63V model, also with RS-232 communication interface instead of RS-485

HIGH-VOLTAGE VERSIONS

Parameter	Value ⁽¹⁾			
Model P/N	SDC-BT-160V	SDC-BT-200V	SDC-BT-250V	SDC-BT-400V
Embedded capacitor bank:				
Voltage (V_{MAX})	160V	200V	250V	400V
Capacitance	2.7mF	2.2mF	1.5mF	820uF
Capacitor charging power supply:				
Buffer voltage	10V...160V	10V...200V	10V...250V	10V...400V
Maximum power in dependence on buffer voltage ⁽²⁾	>100W @ 160V	>100W @ 200V	>100W @ 250V	>100W @ 400V
Diode driver:				
Maximum output current:				
- @ 250us (I_{250})	225A	200A	175A	125A
- @ 300us (I_{300})	200A	175A	150A	100A
Minimum output current (I_{MIN})	10A	10A	10A	5A
Recommended diode voltage ⁽³⁾ :				
- @ I_{300} , 300us	<118V	<144V	<196V	<333V
- @ $\frac{1}{2} I_{250}$, 250us	<137V	<161V	<223V	<357V
Maximum pulse width (T_{MAX})	300us	300us	300us	300us
Minimum pulse width	50us	50us	50us	50us
Maximum repetition rate ⁽⁴⁾	50Hz	50Hz	50Hz	50Hz
Output limitations:				
Energy limit ⁽⁴⁾ ($I_{300} * V_{MAX} * T_{MAX}$)	~9.6J	~10.5J	~11.2J	~12.0J
Power limit	100W	100W	100W	100W
Guaranteed regimes	225A/137V/250us/10Hz 110A/140V/250us/20Hz 50A/120V/250us/50Hz	200A/160V/250us/10Hz 100A/150V/250us/20Hz 50A/110V/250us/50Hz	150A/195V/250us/10Hz 100A/148V/250us/20Hz 50A/105V/250us/50Hz	100A/330V/250us/10Hz 50A/360V/250us/20Hz 50A/100V/250us/50Hz
TEC 1	+	+	+	+
TEC 2	N/A	N/A	N/A	N/A
Alternative versions	on request	on request	on request	SDC-BT-450V
Capacitance	-	-	-	780uF
I_{250} / I_{300}	-	-	-	125A / 100A
I_{MIN}	-	-	-	5A
Recommended diode voltage ⁽³⁾ :	-	-	-	

- @ I_{300} , 300us - @ $\frac{1}{2} I_{250}$, 250us				<371V <403V
Guaranteed regimes	–	–	–	100A/330V/250us/10Hz 50A/360V/250us/20Hz 50A/120V/250us/50Hz

(1) Customizations (e.g. non-standard output currents, non-standard diode voltages and other parameters, software customizations, Pockels cell driver control customizations) are possible on request. Please contact the manufacturer for the details.

(2) In dependence on the topology of the internal DC/DC power converter the dependence of the output power of the capacitor charger from the output voltage is principally different for different models of SDC-BT. Low-voltage models deliver full output power in a wide range of the output voltages. Unlike them, high-voltage models are able to deliver full output power close to V_{MAX} only. At lower output voltages the output power of high-voltage models drops approximately linearly with the decreasing output voltage.

(3) Please note that the output voltage applied to the diodes is always lower than the buffer voltage due to voltage drops across internal components and wiring. The higher output current and pulse width are, the lower output voltage is possible with the same buffer voltage. On the contrary, the possible output voltage reaches exactly the buffer voltage at very low currents and pulse widths.

(4) If the diode voltage is close to V_{MAX} and the operating current is close to I_{MAX} , the typical pulse energy is ~10–15J, and 50Hz operation is not possible due to the 100W average power limitation. Therefore, 50Hz operation is only possible when the operating current and/or voltage are several times lower than I_{MAX} and V_{MAX} , respectively. In such cases, it may be reasonable to consider a low-current version of the driver.

Examples:

- SDC-BT-400V – fully standard 400V version with all the parameters as given above
- SDC-BT-250V-RS232 – standard 250V version, but with RS-232 communication interface

Appendix 1: Software description

STARTUP SCREEN



This screen is shown only at SDC-BT startup. If neither PC nor other controlling device is connected, the **Main screen** must appear after a few seconds (5-10s max.). Otherwise, **USB / RS-485 mode screen** will appear shortly.

SFW: X.X – SDC-BT software version.

MAIN SCREEN



Since the screenshot above is taken with SDC-BT-400V, TEC2 related parameters are hidden.

Monitors:

- TEC1 – TEC 1 actual temperature, °C
- Status indicator – see the **TEC control screen** section for a description
- TEC2 – TEC 2 actual temperature, °C
- Status indicator – see the **TEC control screen** section for a description
- PCD – actual output voltage of the Pockels cell driver. For Pockels cell drivers without a voltage monitor, this field is empty
- Status indicator – see the **Pockels cell driver control and synchronizations screen** section for a description
- Buffer – actual buffer voltage, volts
- Status indicator – see the **Diode control screen** section for a description
- Current – actual pulse current value during the last pulse, amperes
- Status indicator – see the **Diode control screen** section for a description

Synchronizations:

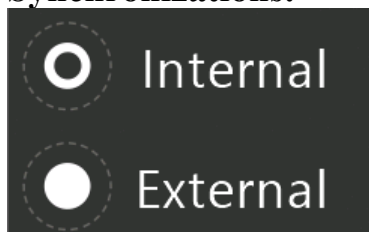

- Internal / External – synchronization mode of the SDC-BT
In internal mode of synchronization, output pulses to diodes are initiated by the internal clock of the SDC-BT.
In external mode of synchronization, output pulses to diodes are initiated by synchronization pulses applied to the SYNC IN BNC connector of the SDC-BT.

Controls:



- TEC1 – TEC 1 enable / disable
- TEC2 – TEC 2 enable / disable
- PCD – Pockels cell driver enable / disable
- Buffer – buffer voltage power source enable / disable
- PDD – diode driver enable / disable

Other:

- IDC status indicator:
Green – IDC circuit is closed
Red – IDC circuit is open
- FAULT status indicator:
Green – no faults detected
Red – SDC-BT fault
- Faults – list of active faults.
List of possible faults is given in the [Faults](#) section.
- Heatsink – internal temperature of the SDC-BT, °C.
- Pulses – pulse counter of the SDC-BT.
- SAVE TO EEPROM button – saves all presets (except **Setup screen** parameters) to device's memory (otherwise all presets will be lost at power off). **Setup screen** parameters are saved independently with APPLY CHANGES button of the corresponding screen.

TEC CONTROL SCREEN



Since the screenshot above is taken with SDC-BT-400V, TEC2 related parameters are hidden.

TEC1, C – temperature set point of TEC 1.

Status indicator nearby:

- **Gray** – TEC is disabled
- **Blue** – TEC is enabled, and thermal stabilization hasn't been achieved yet
- **Green** – TEC is enabled, and thermal stabilization has been achieved
- **Red** – TEC failure (the temperature is out of range)

TEC2, C – temperature set point of TEC 2.

Status indicator nearby:

- **Gray** – TEC is disabled
- **Blue** – TEC is enabled, and thermal stabilization hasn't been achieved yet
- **Green** – TEC is enabled, and thermal stabilization has been achieved
- **Red** – TEC failure (temperature is out of range)

POCKELS CELL DRIVER CONTROL AND SYNCHRONIZATIONS SCREEN



PARAMETER	DESCRIPTION
PCD VOLTAGE	Sets the Pockels cell driver output voltage.
PCD VOLTAGE STATUS INDICATOR	Indicates the status of the Pockels cell driver: <ul style="list-style-type: none"> • Gray – PCD is disabled • Green – PCD is enabled
PCD DELAY	In QBD mode (see also the description of the PCD – Pockels cell driver control mode on the Setup screen), the delay between the leading edge of the TTL pulse applied to the Pockels cell driver and the trailing edge of the current pulse of the SDC-BT. PCD DELAY can be positive or negative. N/A in QBU mode.
SYNC DELAY	The delay between the leading edge of the TTL pulse applied to the SYNC OUT and the trailing edge of the current pulse of the SDC-BT. SYNC DELAY can be positive or negative.

DIODE CONTROL SCREEN

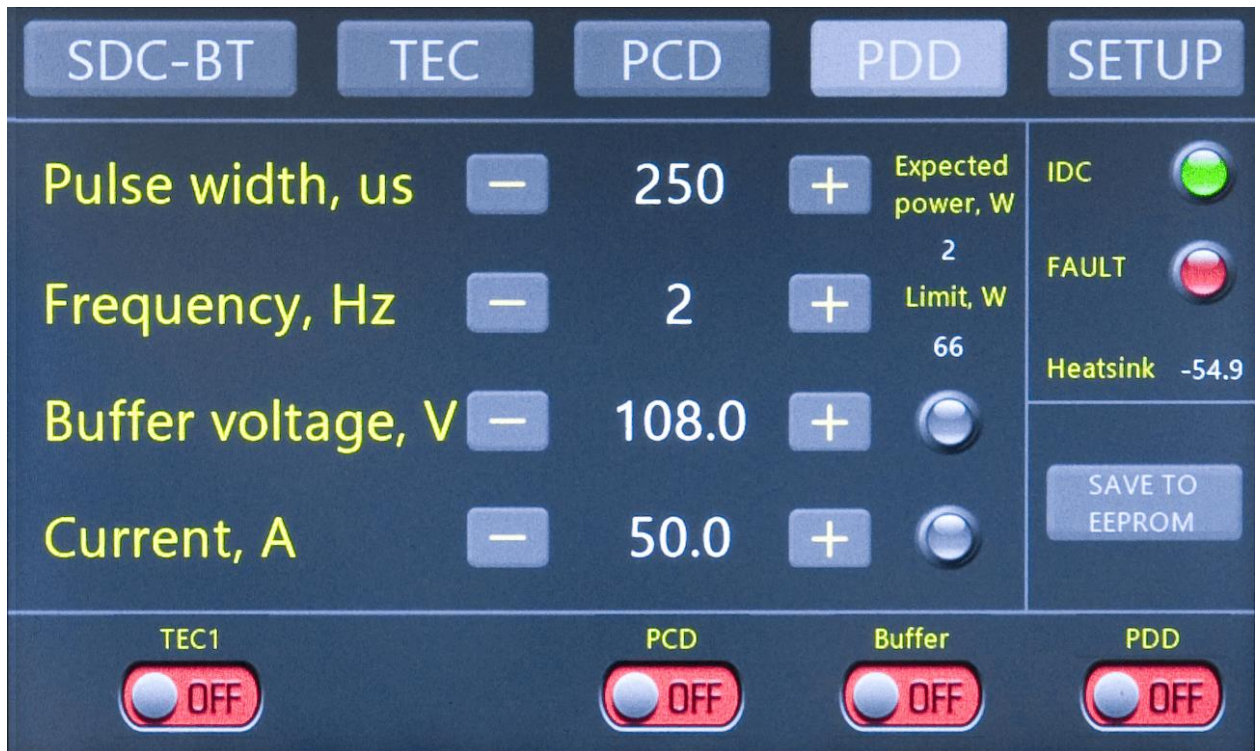

Since the screenshot above is taken with SDC-BT-400V, TEC2 related parameters are hidden.

PARAMETER	DESCRIPTION
PULSE WIDTH	Sets the desired pulse width (both in internal and external synchronization modes). Please note that the diode driver pulses are forcibly limited to 70us when the selected buffer voltage is too high.
FREQUENCY	Sets the desired repetition rate (in internal synchronization mode only).
BUFFER VOLTAGE	Sets the buffer voltage. Buffer voltage should be set a few volts higher than the actual diode voltage. Please follow the Operations section for buffer voltage adjustment instructions.
BUFFER VOLTAGE STATUS INDICATOR	Indicates the status of the buffer voltage subsystem: <ul style="list-style-type: none"> • Gray – the buffer voltage power source is disabled • Blue – the buffer voltage power source is enabled, but the buffer capacitor hasn't been completely charged yet • Green – the buffer voltage power source is enabled, and the buffer capacitor is charged successfully • Red – the buffer voltage power source failure
CURRENT	Sets the desired output current.

CURRENT STATUS INDICATOR	<p>Indicates the status of the diode driver:</p> <ul style="list-style-type: none"> • Gray – the diode driver is disabled • Green – the diode driver is enabled, the buffer voltage is ok • Blue – the diode driver is enabled; the set buffer voltage is not sufficient to generate a current pulse of the specified value or diodes are not connected. Please check that the diodes are connected properly and then increase the buffer voltage slightly. • Red – the diode driver is enabled; the selected buffer voltage is too high (diode driver pulses are forcibly cut down to 70us, please decrease the buffer voltage slightly)
EXPECTED POWER	<p>Expected average output power.</p> <p>Expected average output power is calculated as $I \cdot V \cdot p \cdot t$, where:</p> <ul style="list-style-type: none"> - I – current set point - V – buffer voltage set point - p – frequency set point - t – pulse width set point <p>The SDC-BT will block the operation if the expected power exceeds the power limit value.</p>
LIMIT	<p>The maximum allowed average output power, can be set by the customer.</p>

SETUP SCREEN

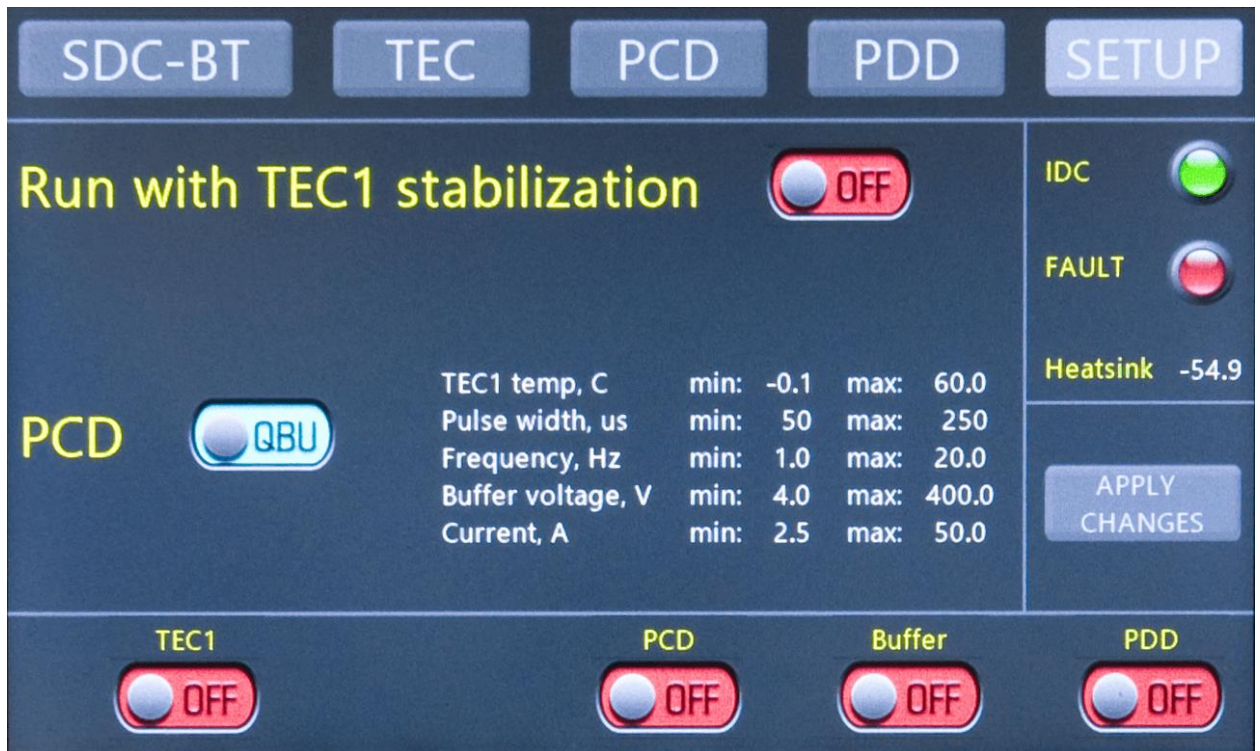

Since the screenshot above is taken with SDC-BT-400V, TEC2 related parameters are hidden.

The parameters entered on this screen must be saved by clicking the APPLY CHANGES button before leaving the screen; other screens do not require this.

Run with TEC1 stabilization – if ticked, the diode driver cannot be enabled until TEC 1 has run, and stabilization is achieved.

Run with TEC2 stabilization – if ticked, the diode driver cannot be enabled until TEC 2 has run, and stabilization is achieved.

PCD – Pockels cell driver control mode:

- if set to “QBD”, a trigger pulse applied to the Pockels cell driver is adjustable and shifted relatively **the trailing edge** of the current pulse of the SDC-BT accordingly to the PCD DELAY parameter (see also the description of PCD DELAY parameter on the **Pockels cell driver control and synchronizations screen**). Pulse width is 5us, fixed.
- if set to “QBU”, a trigger pulse applied to the Pockels cell driver repeats the diode driver pulse.

APPLY CHANGES button – saves the parameters (from this screen only) to the EEPROM memory of the device.

The screen also depicts min/max limits of some parameters. They can be changed via RS-232 / RS-485 interface or PC software only.

USB / RS-485 MODE SCREEN



This screen appears only if SDC-BT is run either in USB or in RS-485 mode.

Appendix 2: RS-232 / RS-485 communication protocol, its description

A complete description of the current version of the RS-485 communication protocol is supplied with the SDC-BT diode driver. Please request the description from the manufacturer if you need it in advance.

Appendix 3: Demo PC software, its description

Additionally, we provide a demo software utility, which is supplied for free together with SDC-BT-series diode drivers to simplify their integration into high-level customer's systems. Please request the description from the manufacturer if you need it in advance.

SDC-series demo software utility

COM4 Silicon Labs CP210x USB to UART Bridge (C) Refresh Connect Green indicator

Parameters

Current, A: 50.0 Start

Pulse width, us: 250

Frequency, Hz: 20.0

Buffer voltage, V: 300.0 Buffer

TEC1, C: 20.0 TEC1

PCD voltage, kV: 4.00 PCD

PCD delay, us: 0

Sync out delay, us: 0

Sync

Internal

External 1

External 2

Fault

Interlock

Discharge

Save parameters

TEC graph

Status

Radiator temp.	-40.3 C
PCB temp.	30.4 C
Input voltage	20.1 V
Buffer voltage	0.0 V
TEC1 current	0.0 A
TEC1 temp.	25.2 C
Diode current	0.0 A
Transistor voltage	0.0 V
Expected power	75 W
Freq. ext. max.	26.6 Hz
Pulse counter	0

Faults

OVERHEAT1	<input type="checkbox"/>
VOLTLOW	<input type="checkbox"/>
VOLTHIGH	<input type="checkbox"/>
TEC1	<input type="checkbox"/>
TEC2	<input type="checkbox"/>
OVERHEAT2	<input type="checkbox"/>
IDC	<input checked="" type="checkbox"/>
DCDC	<input type="checkbox"/>
POWER	<input type="checkbox"/>
TECNR	<input type="checkbox"/>

Stop reasons

OVERHEAT1	<input type="checkbox"/>
OVERHEAT2	<input type="checkbox"/>
DCDC	<input type="checkbox"/>
POWER	<input type="checkbox"/>
TECNR	<input type="checkbox"/>
RS_TIMEOUT	<input type="checkbox"/>
IDC	<input type="checkbox"/>
USER	<input type="checkbox"/>

Appendix 4: Embedded version

An embedded version (without enclosure, for integration into customer systems) is available on request. Please see description of [SDC-200 diode drivers](#) for the details.

