

SDC-4U diode driver

User manual

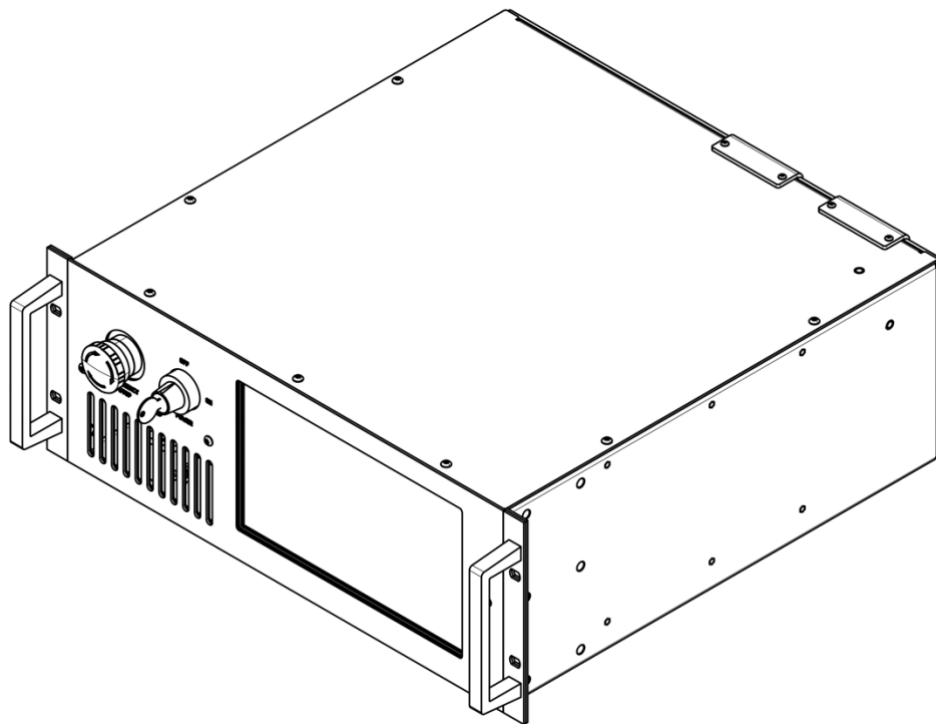

Warning! This equipment can be dangerous.
Please read this entire user manual carefully before operating the product.

Table of contents

Table of contents	2
Overview / Appearance	3
Cooling	4
Contents of delivery	4
Front panel description	5
Back panel description	5
Safety	8
Installation	8
Operations.....	8
Technical notes	10
Specifications	11
Dimensional drawing.....	13
How to order?	14
Appendix 1: UI software description	16
Appendix 2: RS-232 / RS-485 communication protocol, its description.....	23
Appendix 3: Demo PC software, its description	23
Appendix 4: Embedded version	24

Overview / Appearance

SDC-4U is a family of laser diode drivers designed for pumping high-power Nd:YAG-like solid-state lasers. The driver has an embedded current source, capacitor bank and capacitor charger (see also the full driver's architecture in the picture on the next page). Some modifications also capable of powering and controlling a Pockels cell driver for generation of Q-switched pulses. The SDC-4U can send output synchronization signals to other equipment, either coincident with the TTL pulse applied to the Pockels cell driver or shifted relative to it.



Main features of the SDC-4U driver (may vary by part number):

- Wide-range 110-240VAC input.
- High compliance voltage – up to 500V (model dependent).
- High output current – up to 400A (model dependent).
- High average power – up to 1500W.
- Pulse widths are typical for Nd:YAG pumping (50-300us, wider on request), rise and fall times are fast (tens of microseconds), pulse repetition rates can be as high as 50Hz and more.
- Internal and external synchronization modes.
- Control of an external Pockels cell driver (purchased separately and connected to the SDC-4U driver from outside).

- Multiple outputs and other customizations are available on request.

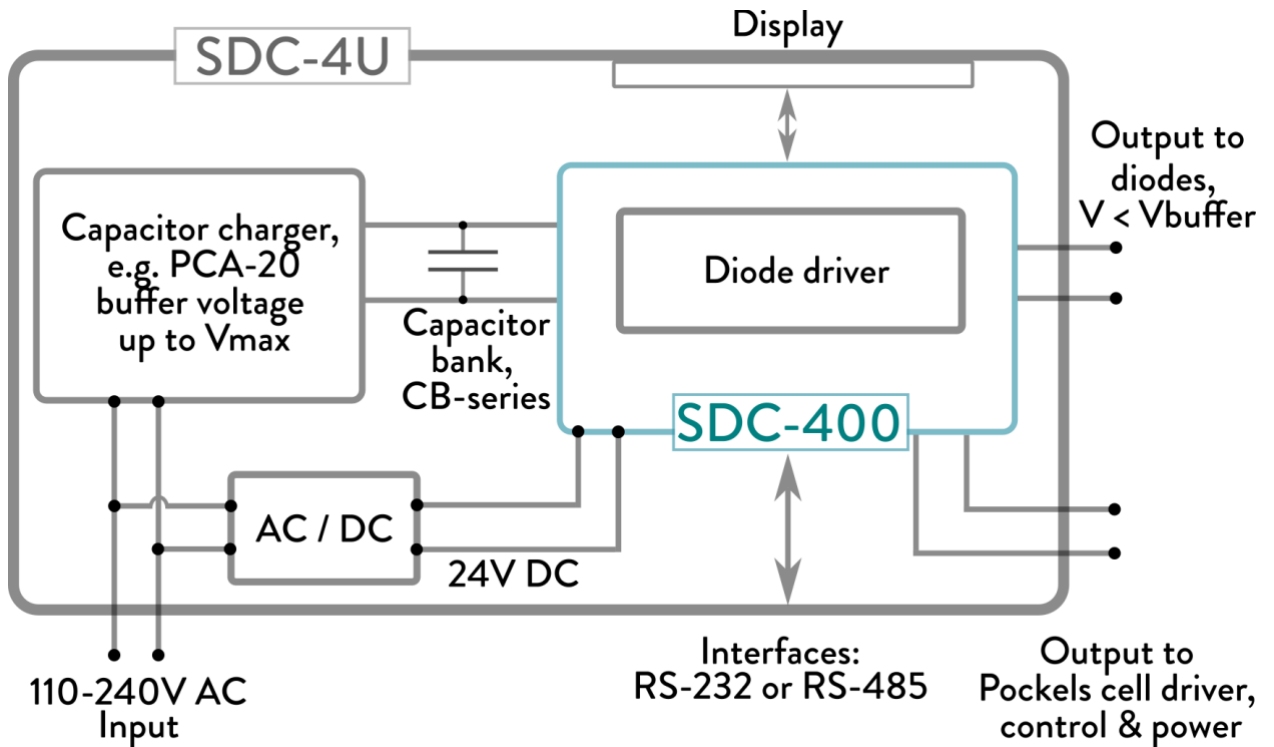

The SDC-4U high-power diode drivers are designed for 19-inch rack mounting, with a 4U height and approximately 500mm depth.

All the important parameters (output current, buffer voltage, pulse width, pulse repetition rate and others) can be configured via the front panel user interface (10" color touchscreen display) or through the RS-232 interface (RS-485 is available upon request).

Cooling

The driver is cooled by built-in fans. External cooling is not required.

Contents of delivery

By default, the delivery package contains the following parts:

- SDC-4U diode driver – 1pc
- Power cord (European plug) – 1pc
- Diode connection cables (200cm length) – 1set
- Interface 1 cable (50cm length) – 1pc
- Interface 2 cable (50cm length) – 1pc
- USB Flash drive with software and documentations – 1pc

Front panel description



ELEMENT	DESCRIPTION
EMERGENCY STOP PUSH BUTTON	Stops operations when pressed. Must be released to allow operations.
KEY LOCK POWER SWITCH	Switches the driver on and off.

Back panel description



ELEMENT	DESCRIPTION
AC INPUT	Connects the driver to the mains (110-240VAC, 50/60Hz, single phase).
FUSES	2x fuses (Ø6.3x32mm, 16A rating).
SYNC IN	Incoming synchronization pulses should be applied here when the driver operates in the external synchronization mode.
SYNC OUT 1	Synchro output signal coinciding with the TTL pulse applied to the

	current source of SDC-4U. 50 Ohm terminators should be used for better waveforms of synchro output signals.
SYNC OUT 2	Synchro output signal coinciding with the TTL pulse applied to the Pockels cell driver. 50 Ohm terminators should be used for better waveforms of synchro output signals.
SYNC OUT 3	Synchro output signal with a fixed length (5us) and with an adjustable delay relatively to the TTL pulse applied to the Pockels cell driver. 50 Ohm terminators should be used for better waveforms of synchro output signals.
INTERFACE 1	Interface connector (RS-232 and IDC).
INTERFACE 2	Interface connector (Pockels cell driver connection).
DIODE “+” DIODE “-”	Diode connections (“+” to anode, “-” to cathode).
CAPACITOR BANK “+” CAPACITOR BANK “-”	Connection for an external capacitor bank. Since most of capacitor banks are composed of electrolytic capacitors, the correct polarity is critical.
GND	Protective grounding of the driver.

INTERFACE 1 (RS-232)

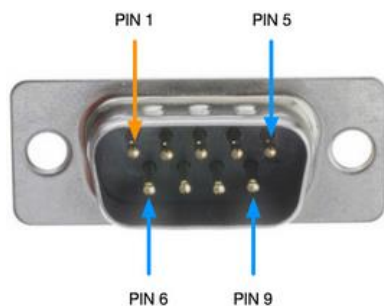

PIN (COLOR)	DESIGNATION
2 (blue)	RS-232 RX
3 (orange)	RS-232 TX
5, 8 (black)	RS-232 GND
6 (green)	IDC (Interlock)
7 (transparent)	IDC Return

INTERFACE 2 (PCD CONTROL)

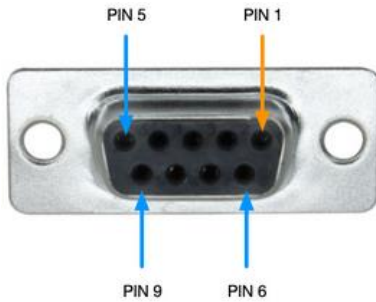

PIN (COLOR)	DESCRIPTION
2 (red)	24VDC power to the Pockels cell driver
3 (blue)	Q-switch / Pulse (5V TTL)
4 (green)	Enable (5V TTL)
5 (yellow)	Voltage Program (analogue signal 0-10V)
9 (black)	GND

GROUNDING AND MOUNTING

The SDC-4U driver must be protectively grounded via the provided ground stud at all times during operation.

Grounding policy

RS-232 GND, IDC Return, SYNC IN GND, SYNC OUT GND are isolated from each other and from the device ground (chassis).

All synchro outputs share the same ground.

Interface 2 GND is internally connected to the device ground (chassis).

Other grounding policies are available on request.

Safety

Warning! This equipment produces high voltages that can be very dangerous. Be careful around the device.

- During operation all the protective covers of the equipment must be securely fixed in place, and all electrical connections must be properly attached.
- The SDC-4U diode driver must be protectively grounded at all times during operation.
- It is the user's responsibility to ensure that unauthorized personnel are protected from accidentally coming into contact with the SDC-4U, especially CAPACITOR BANK and DIODE connectors and cables.
Accidental contact could be fatal!
- After shutdown, do not handle the capacitive load until it has been fully discharged. Always use an appropriate meter to verify complete discharge before proceeding.
- Disconnect the driver from the AC power source before making or changing electrical or mechanical connections.
- **Do not remove protective covers!** There are no user-serviceable parts inside this equipment.

Installation

- Mount the SDC-4U diode driver.
- Ground it, using the provided grounding stud.
- Connect your diode to the DIODE output.
- Ensure that diode's anode and cathode are isolated from the ground.
- Organize your interlock connection or install the IDC choke instead.
- If necessary, connect your Pockels cell driver to the driver's PCD CONTROL connector.
- If connection to PC is required, connect the driver to the PC via RS-232 connector. Install the Windows software from the USB flash drive supplied together with the SDC-4U driver. Use an appropriate USB/RS-232 adapter.
- Connect the driver to the mains.

Operations

- Turn on the diode driver using the key lock POWER switch. If necessary, release the EMERGENCY STOP button first.
- Then set the desired output parameters on the **Diode driver screen** of the SDC-4U.

- Set the output current low (e.g. to 20% of the maximum diode current), set the repetition rate also low (e.g. to a few Hertz).
- Set the desired buffer voltage accordingly to the V/A curve given in the diode datasheet.
- Slide the *BUFFER* switch on and wait until the internal capacitor bank is fully charged (i.e. check the *BUFFER VOLTAGE STATUS INDICATOR* on the **Main screen** or **Diode driver screen** of the SDC-4U).
- Slide the *PDD* switch on to start current pulses to the output.
- Monitor the *CURRENT STATUS INDICATOR* color:
 - If it is red: decrease the buffer voltage until the *CURRENT STATUS INDICATOR* turns green, then continue decreasing it until the *CURRENT STATUS INDICATOR* turns blue. After that increase the buffer voltage again by an additional 2–3V for stable operation
 - If it is blue: increase the buffer voltage until the *CURRENT STATUS INDICATOR* turns green, then increase it by an additional 2–3V for stable operation.
- Increase the output parameters as necessary. If needed, repeat the buffer voltage adjustment procedure.
- To shut down the driver, slide the *PDD*, *BUFFER* and other switches off, then turn off the unit using the key lock POWER switch.

Technical notes

OUTPUT CABLES

The output cables inductance affects the SDC-4U performance. The higher inductance is, the higher current overshoot is. For better performance, we recommend keeping inductance of the output cables below 500nH. The recommended length of the output cables is 50cm or shorter.

However, the SDC-4U allows to adjust the rise time to suppress current overshoot when the longer output cables are used.

OUTPUT MEASUREMENT AND GROUNDING

Neither the DIODE “+” nor the DIODE “-” driver outputs may be grounded. Grounding either the DIODE “+” or DIODE “-” output may result in driver failure.

For the same reasons, do not connect an oscilloscope probe ground to DIODE “-” when measuring the output voltage. We recommend using differential probes for direct output voltage measurements.

Specifications

ELECTRICAL

Input:	
Input voltage	110-240VAC, 50/60Hz, 1ph
Output:	
Regime of operations	Pulsed
Maximum buffer voltage (V_{MAX})	Model dependent (user selectable up to 500V), other on request
Maximum output voltage	Model dependent (see also How to order? section), other on request
Maximum output current (I_{MAX})	Model dependent (user selectable up to 400A), other on request
Output current	Adjustable in 10...100% of I_{MAX} range, other on request
Buffer voltage	Adjustable in 30- V_{MAX} range, other on request
Pulse width	Adjustable in 50-300us range, other on request
Pulse repetition rate	Adjustable up to 50Hz, other on request
Maximum average output power	1500W, other on request
Rise time	<20-30us typically, slow start adjustable in 0...50us range
Capacitor bank:	
Capacitance	Model dependent (5mF to 20mF), other on request
Extension slot	+
Recommended cables:	
For diode connections	Inductance – <500nH Cross-section – 4mm ² Length – <50cm (up to 2m acceptable)
For external capacitor bank connections	Cross-section – 4mm ² Length – <50cm
Protections / safety:	From overcurrent From overheating From incorrect buffer voltage

	From too high frequency of synchronization pulses Door-interlock connection Quick discharge resistors (4kOhm)
Cooling:	Forced-air cooling with built-in fans
Interfaces:	UI – 10” display with touchscreen RS-232 / RS-485 serial interface
Synchronizations:	1pc synchro input 3pcs synchro outputs
Environmental:	
Operating temperature	+10 ... +40 °C
Storage temperature	-20 ... +60 °C
Humidity	<90%, non-condensing

MECHANICAL

Size (LxWxH)	19” rack mountable, 4U height, depth around 500mm (see also the dimensional drawing below)
Weight	<15kg

Dimensional drawing

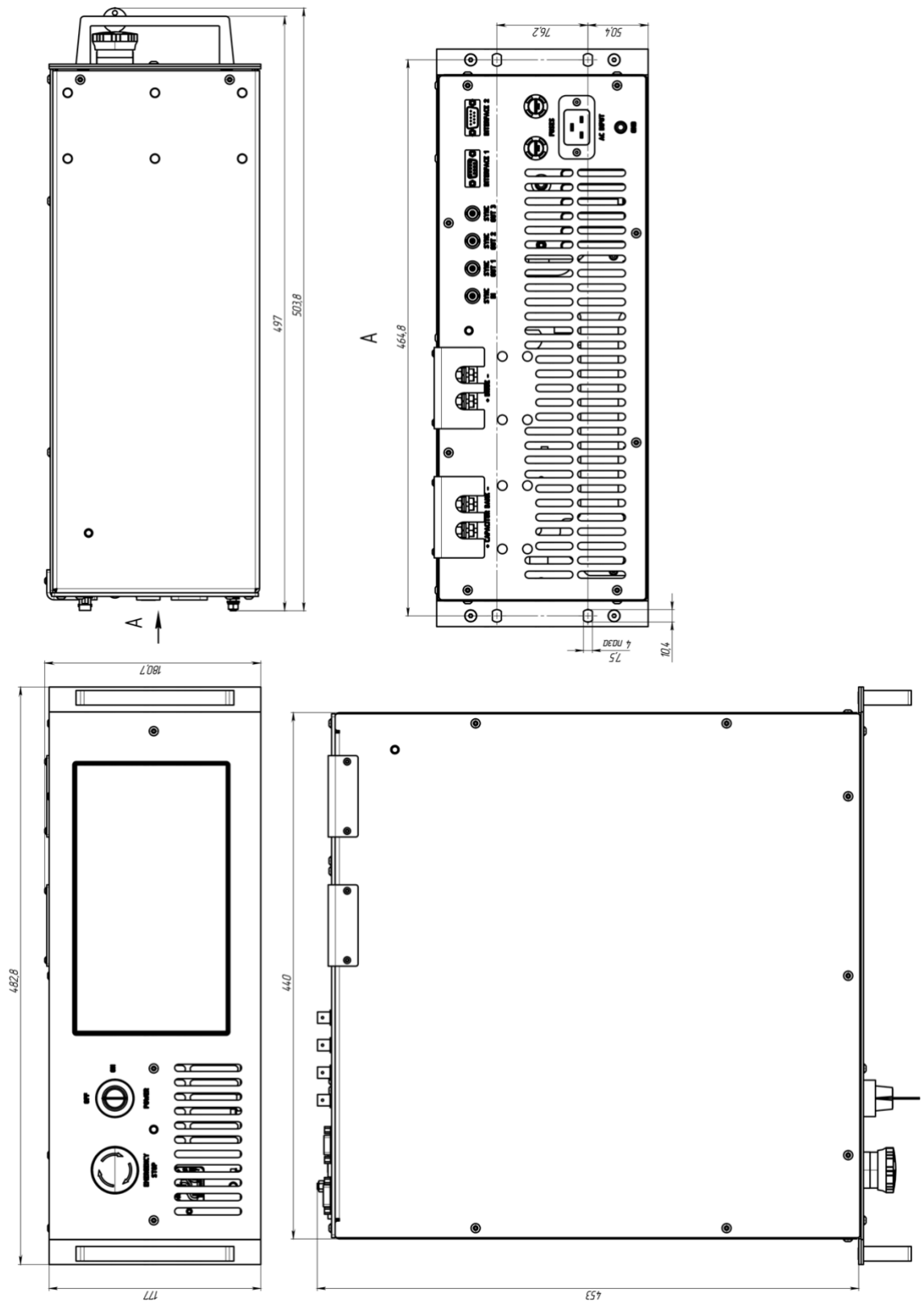

How to order?

SDC-4U-[XX]-YYYY-[VVVVV], where:

- XX code defines the number of output channels, it can be either C1 (single-channel version) or C2 (dual-channel version). By default, C1 version is supplied.
- YYYY codes the voltage version of the driver (nominal value, can be 300V, 350V, 400V, 450V, 500V, or custom). The maximum output current and internal capacitor bank capacitance are fixed for each voltage version, see details in the table below.
- VVVVV code defines the type of serial interface, it can be either RS232 or RS485. The RS232 version of the SDC-4U can control an external Pockels cell driver. Multiple SDC-4U drivers of the RS485 version can operate in master-slave mode. By default, the RS232 version is supplied.

PARAMETER	VALUE (*)				
Model (voltage version)	300V	350V	400V	450V	500V
Embedded capacitor bank:					
Voltage (V_{MAX})	300V	350V	400V	450V	500V
Capacitance	20mF	20mF	13mF	13mF	5mF
Capacitor charging power supply:					
Output voltage (buffer voltage)	30...300V	30...350V	30...400V	30...450V	30...500V
Maximum power in dependence on buffer voltage	>1500W @ 300V	>1500W @ 350V	>1500W @ 400V	>1500W @ 450V	>1500W @ 500V
Diode driver:					
Maximum output current	400A	350A	300A	250A	225A
Recommended diode voltage (**)	<280V	<330V	<380V	<430V	<480V
Pulse width	50us...300us				
Repetition rate	0Hz...50Hz				
Output limitations:					
Energy limit	$I_{max} * V_{max} * T_{max}$				
Power limit	1500W	1500W	1500W	1500W	1500W
Guaranteed regime	400A/280V/ 250us/50Hz	350A/330V/ 250us/50Hz	300A/380V/ 250us/50Hz	250A/430V/ 250us/50Hz	225A/480V/ 250us/50Hz

(*) Customizations (e.g. non-standard output currents, non-standard diode voltages, software customizations, Pockels cell driver control) are possible on request. Please contact the manufacturer for the details.

(**) Please note that the output voltage applied to the diodes is several volts lower than the buffer voltage due to voltage drops across internal components and wiring.

Some examples of typical configurations are given in the table below:

PART NUMBER	DESCRIPTION
SDC-4U-300V	Input voltage – 110-240VAC, 50/60Hz, 1ph Number of output channels – 1 Maximum output voltage – 300V Maximum output current – 400A Embedded capacitor bank capacitance – 20mF @ 300V Maximum output power – 1500W @ 300V RS-232 interface
SDC-4U-C1-400V	Input voltage – 110-240VAC, 50/60Hz, 1ph Number of output channels – 1 Maximum output voltage – 400V Maximum output current – 300A Embedded capacitor bank capacitance – 13mF @ 400V Maximum output power – 1500W @ 400V RS-232 interface
SDC-4U-500V-RS485	Input voltage – 110-240VAC, 50/60Hz, 1ph Number of output channels – 1 Maximum output voltage – 500V Maximum output current – 225A Embedded capacitor bank capacitance – 5mF @ 500V Maximum output power – 1500W @ 500V RS-485 interface

Other modifications are available on request.

Appendix 1: UI software description

STARTUP SCREEN



Under normal circumstances, the **Startup screen** should change to the **Main screen** within a few seconds.

MAIN SCREEN

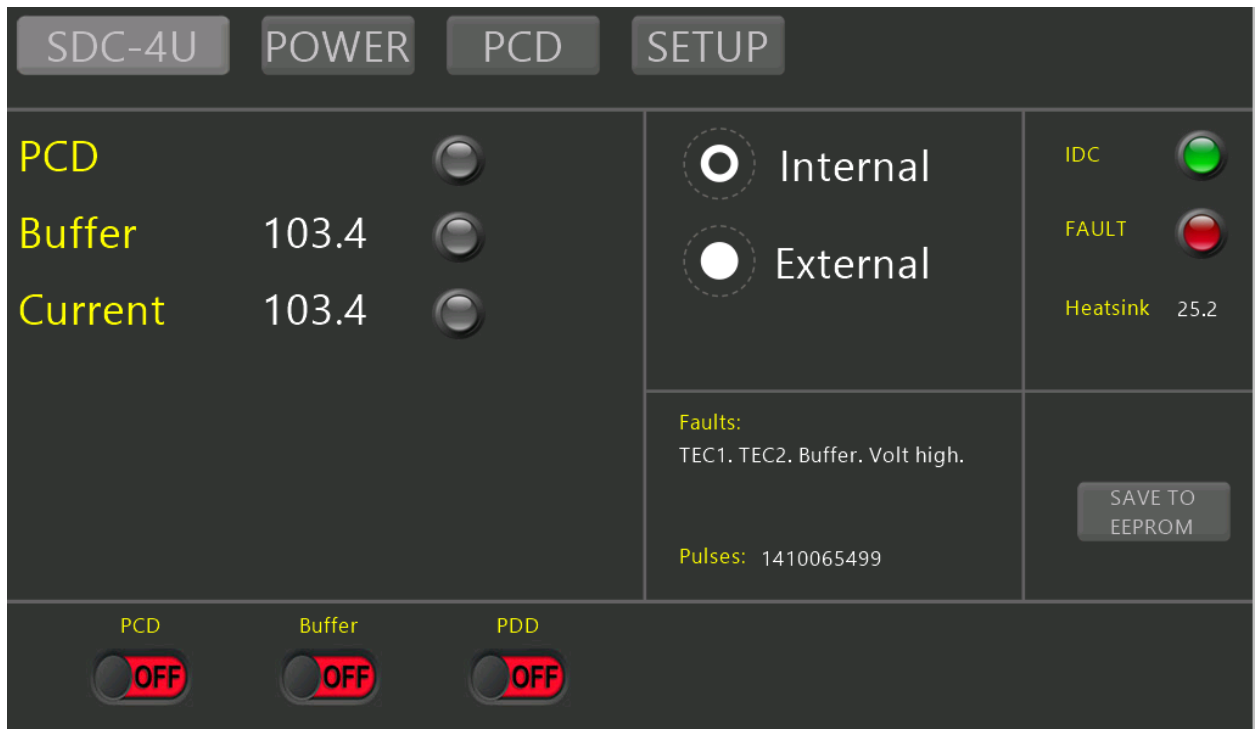

Top section (main menu):



- Allows the navigation between different software screens.
- This section is common for all software screens.

Bottom section (control slider switches):

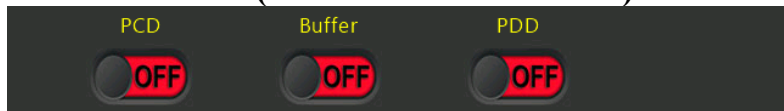

- Switches on/off the major SDC-4U subsystems:
 - Buffer slider for the buffer voltage subsystem.
 - PCD slider for the Pockels cell driver (if in use).
 - PDD slider for the diode driver.
- This section is common for all software screens.

Right section:

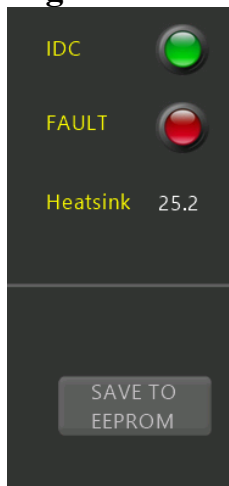

- IDC STATUS INDICATOR – the Interlock-door connection status.
Green – IDC circuit is closed
Red – IDC circuit is open
- FAULT STATUS INDICATOR – Fault status of the SDC-4U driver.
Green – no faults detected
Red – SDC-4U fault
- Heatsink – the temperature of the main driver’s heatsink.
- SAVE TO EEPROM – saves all driver’s parameters to the device’s memory.
- This section is also common for all software screens.

Central section:

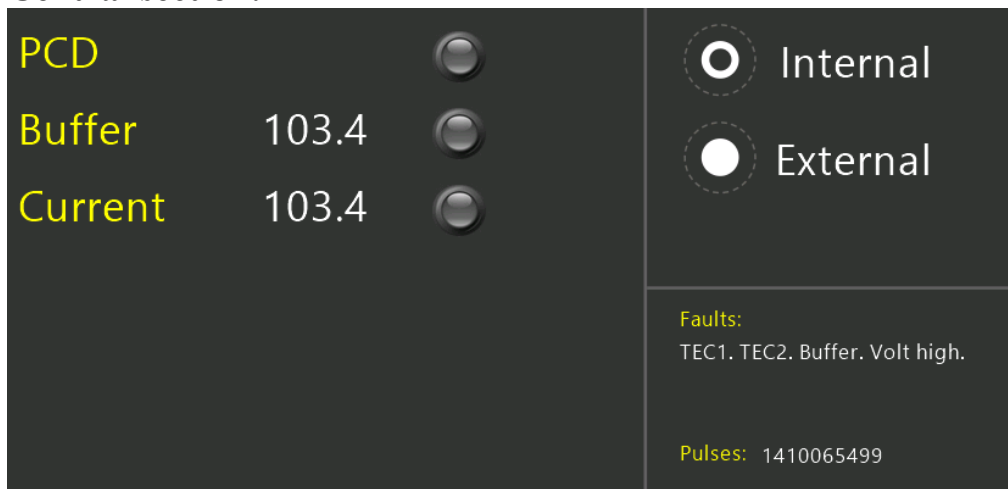

PARAMETER	DESCRIPTION
PCD STATUS INDICATOR	Indicates the status of the Pockels cell driver: <ul style="list-style-type: none"> • Gray – disabled • Green – enabled
BUFFER	Indicates the actual (measured) buffer voltage.
BUFFER VOLTAGE	Indicates the status of the buffer voltage subsystem:

STATUS INDICATOR	<ul style="list-style-type: none"> • Gray – disabled • Blue – the buffer is being charged • Green – the buffer is charged to the set voltage
CURRENT	Indicates the actual pulse current value during the last pulse. Measurements are performed approx. 70us after the pulse start.
CURRENT STATUS INDICATOR	Indicates the status of the diode driver: <ul style="list-style-type: none"> • Gray – the diode driver is disabled • Green – the diode driver is enabled; buffer voltage is ok • Blue – the diode driver is enabled; the selected buffer voltage is too low (please increase the buffer voltage slightly) • Red – the diode driver is enabled; the selected buffer voltage is too high (diode driver pulses are forcibly cut down to 70us, please decrease the buffer voltage slightly)
INTERNAL	Switches the driver to the internal synchronization mode.
EXTERNAL	Switches the driver to the external synchronization mode.
FAULTS	List of active faults. Full list of all possible faults is given below: <ul style="list-style-type: none"> • OVERHEAT1 – main heatsink overheating • OVERHEAT2 – diode driver PCB overheating • VOLTLOW – buffer voltage is too low • VOLTHIGH – buffer voltage is too high • IDC – door-interlock circuit is open • DCDC – failure of the internal capacitor charging power supply • POWER – maximum output power limit exceeded
PULSES	Pulse counter of the device.

DIODE DRIVER SCREEN

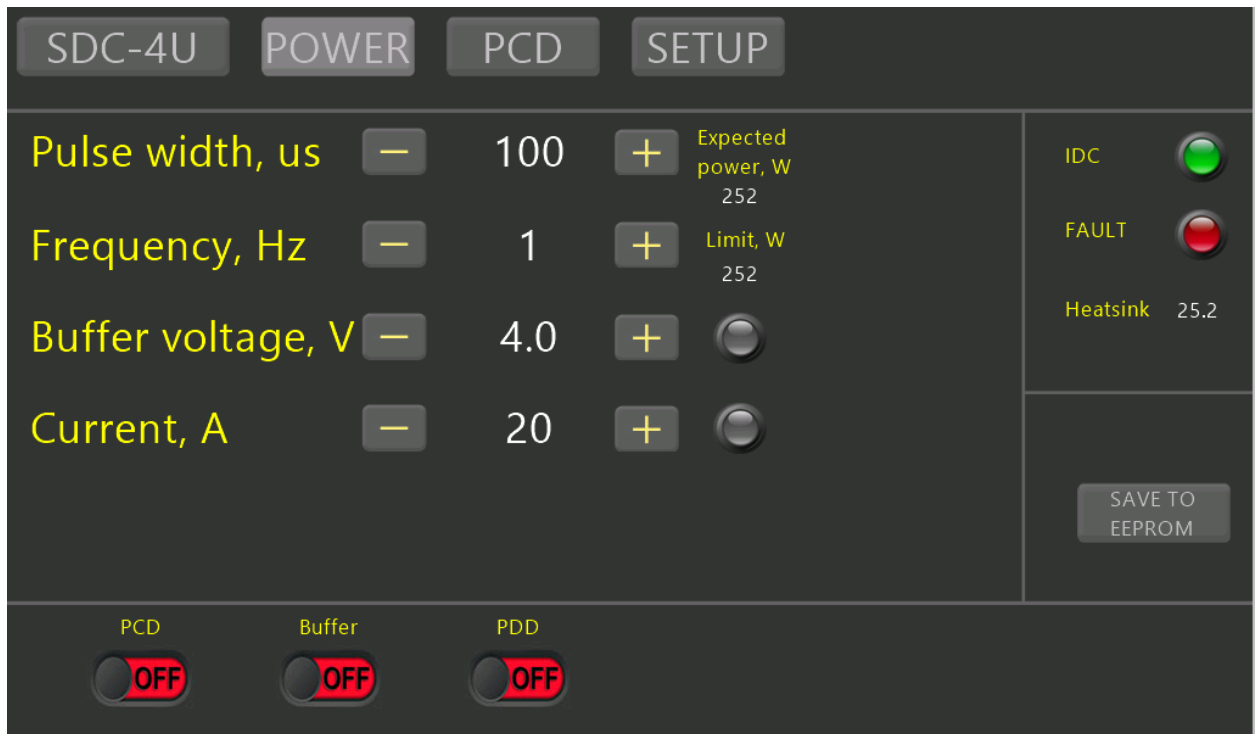

PARAMETER	DESCRIPTION
PULSE WIDTH	Sets the desired pulse width (both in internal and external synchronization modes). Please note that the diode driver pulses are forcibly limited to 70us when the selected buffer voltage is too high.
FREQUENCY	Sets the desired repetition rate (in internal synchronization mode only).
BUFFER VOLTAGE	Sets the buffer voltage. Buffer voltage should be set 5-10V higher than the actual diode voltage. Please follow the Operations section for buffer voltage adjustment instructions.
BUFFER VOLTAGE STATUS INDICATOR	Indicates the status of the buffer voltage subsystem. Duplicates the BUFFER VOLTAGE STATUS INDICATOR on the Main screen (see the description in the corresponding section).
CURRENT	Sets the desired output current.
CURRENT STATUS INDICATOR	Indicates the status of the diode driver. Duplicates the CURRENT STATUS INDICATOR on the Main screen (see the description in the corresponding section).
EXPECTED POWER	Expected average output power. Expected average output power is calculated as $I \cdot V \cdot p \cdot t$, where: - I – current set point - V – buffer voltage set point

	- p – frequency set point - t – pulse width set point
LIMIT	The maximum allowed average output power.

POCKELS CELL DRIVER AND SYNCHRONIZATIONS SCREEN

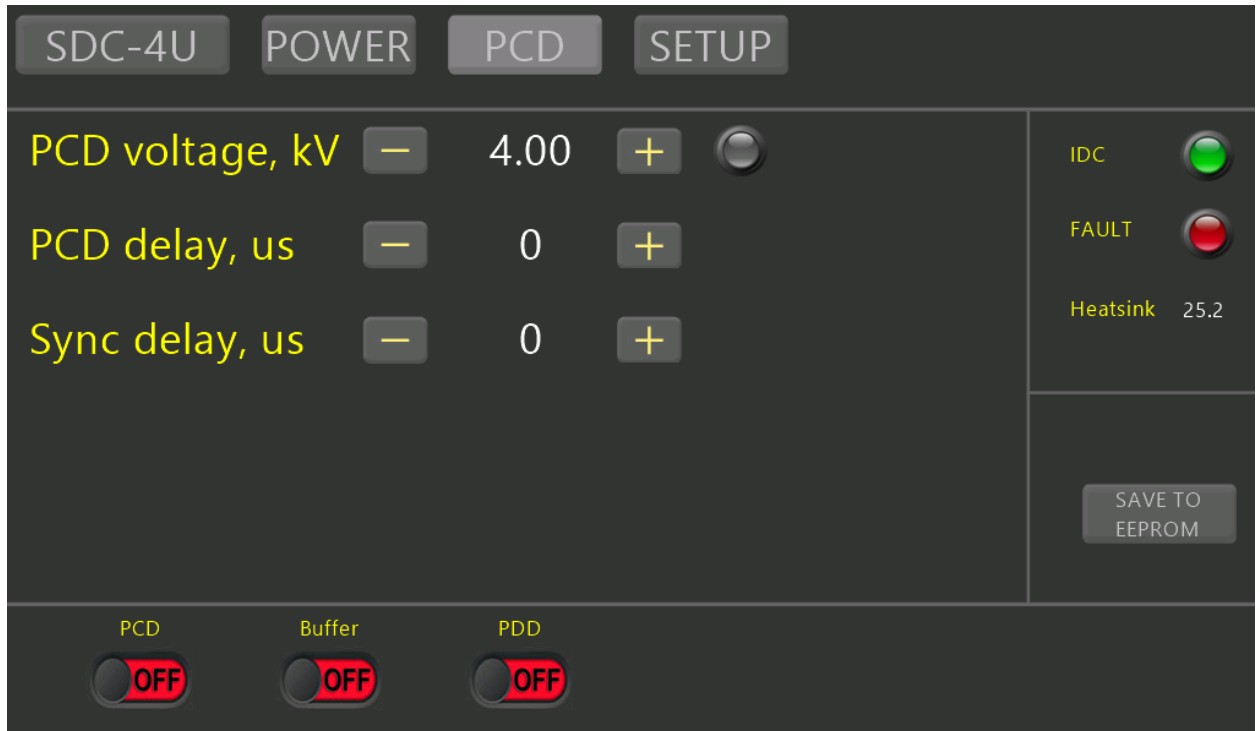

PARAMETER	DESCRIPTION
PCD VOLTAGE	Sets the Pockels cell driver output voltage.
PCD VOLTAGE STATUS INDICATOR	Indicates the status of the Pockels cell driver. See description of the corresponding status indicator in the Main screen section.
PCD DELAY	The delay between the leading edge of the TTL pulse applied to the Pockels cell driver and the trailing edge of the TTL pulse applied to the diode driver of SDC-4U (trailing edge of the SDC-4U output current pulse). PCD DELAY can be positive or negative.
SYNC DELAY	The delay between the leading edge of the TTL pulse applied to the SYNC OUT 3 and the leading edge of the TTL pulse applied to the Pockels cell driver. SYNC DELAY can be positive or negative.

SETUP SCREEN

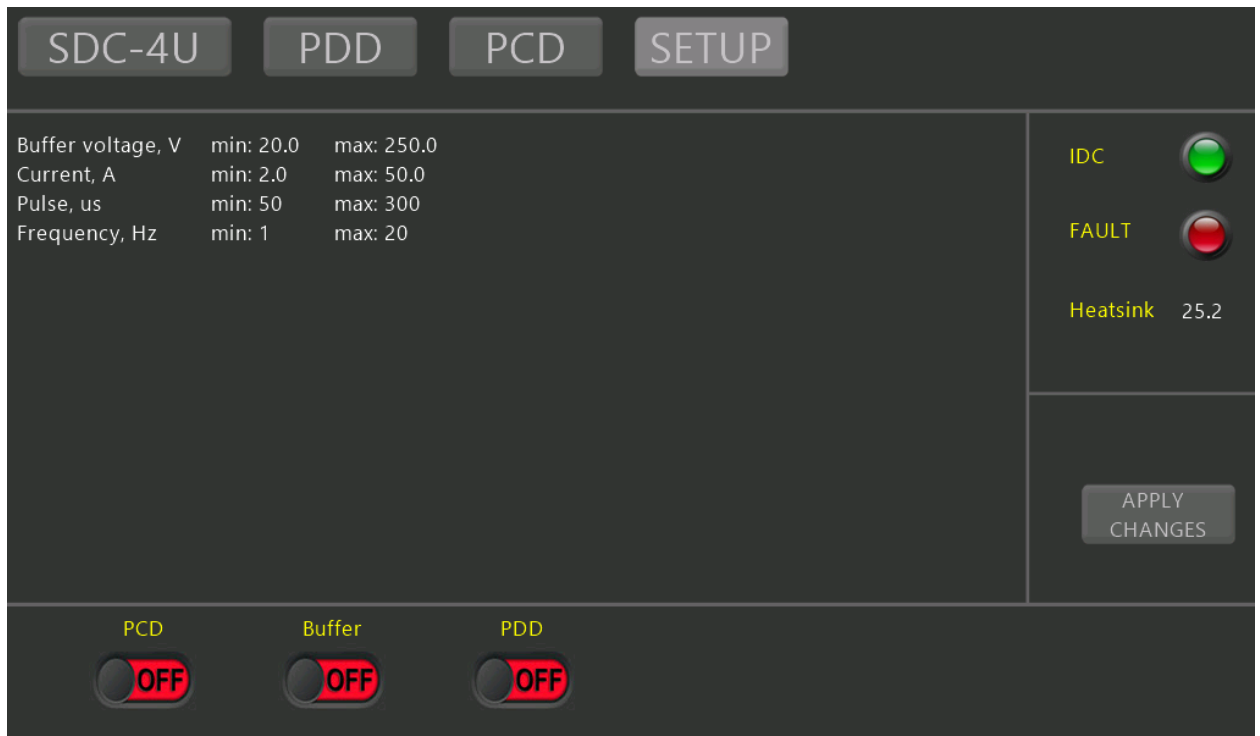

The screen contains the information about the limits of the main operating parameters as well as some other preferences.

Appendix 2: RS-232 / RS-485 communication protocol, its description

A complete description of the current version of the RS-485 communication protocol is supplied with the SDC-4U diode driver. Please request the description from the manufacturer if you need it in advance.

Appendix 3: Demo PC software, its description

Additionally, we provide a demo software utility, which is supplied for free together with SDC-series diode drivers to simplify their integration into high-level customer's systems. Please request the description from the manufacturer if you need it in advance.

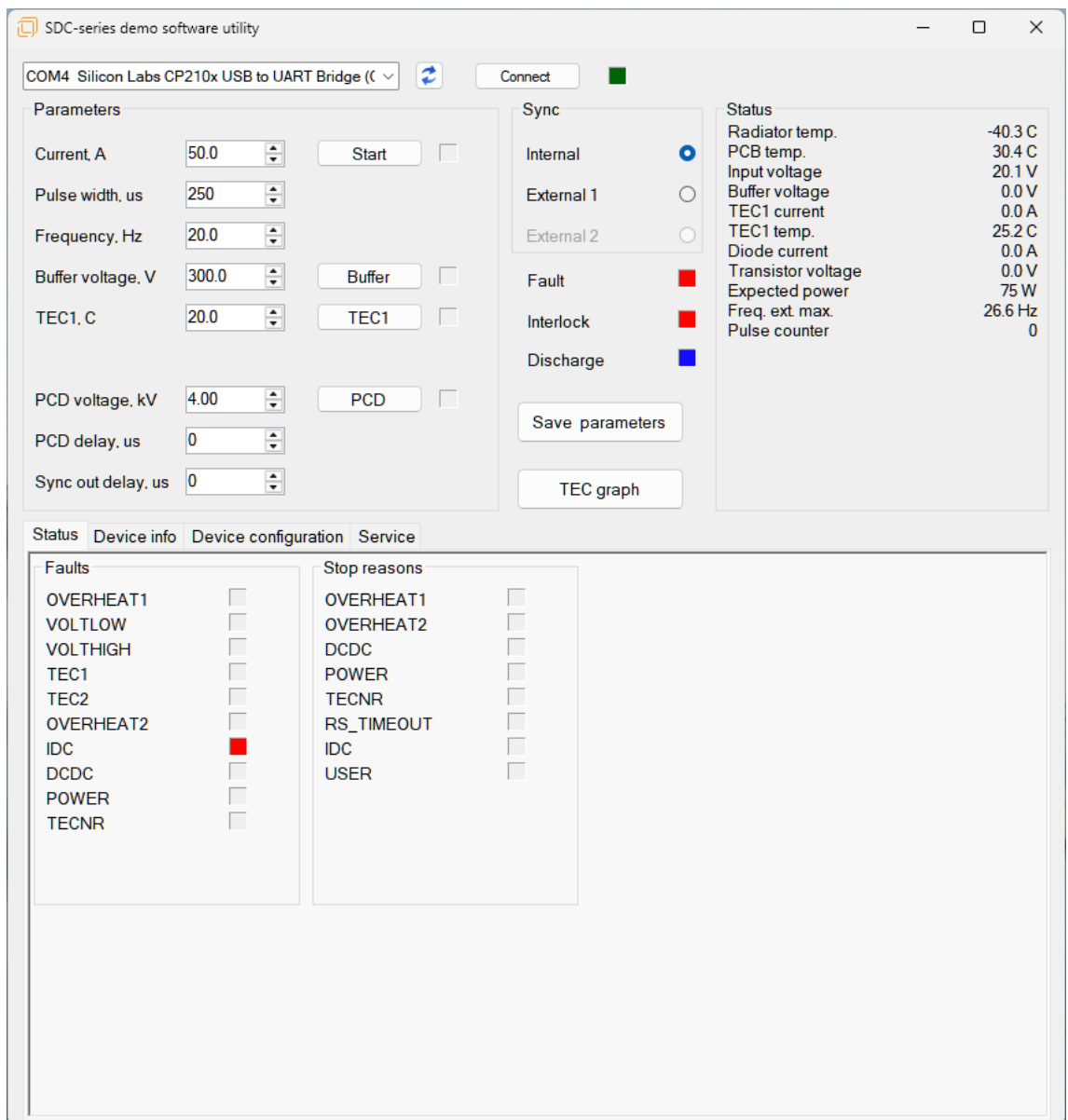

Appendix 4: Embedded version

An embedded version (without enclosure, for integration into customer systems) is available on request in options with water and forced-air cooling. Please see description of [SDC-400 diode drivers](#) for the details.

FORCED-AIR COOLING

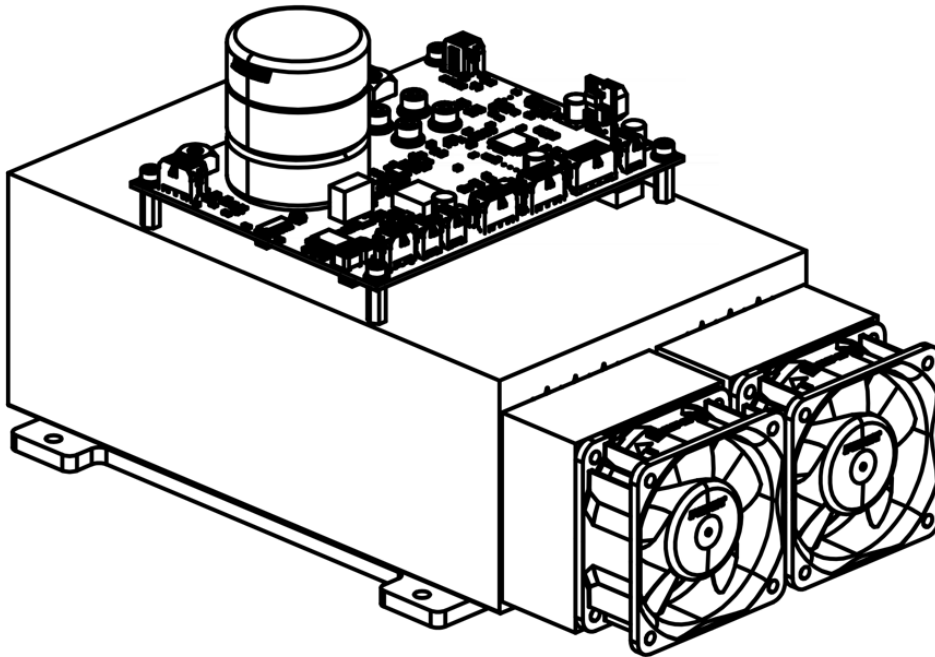

WATER COOLING

