

## NBU-1312 discharge circuit

### User manual

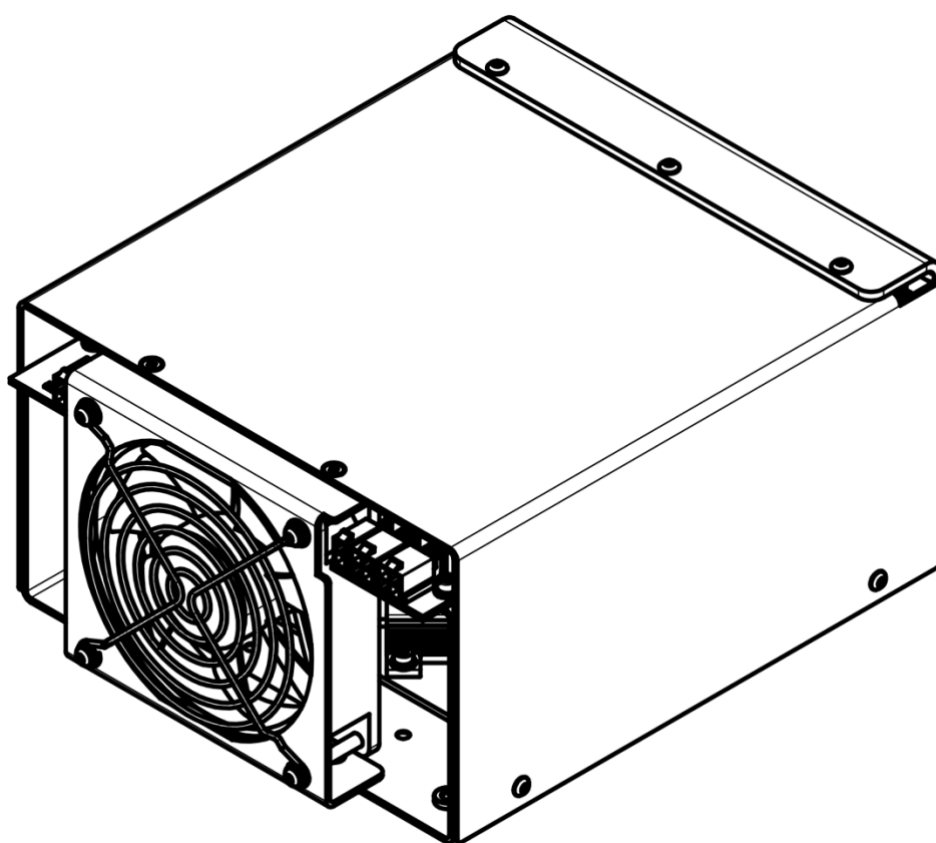

**Warning!** This equipment may be dangerous.  
Please read the entire user manual carefully before using the product.

## Table of contents

---

Table of contents .....	2
Overview / Applications.....	3
Cooling .....	3
Appearance .....	4
Contents of delivery .....	4
Connections, signals, signal descriptions .....	5
Safety .....	9
Operations.....	10
Specifications .....	11
Dimensional drawing.....	13
How to order? .....	14
Triggering (series triggering, external triggering, triggering basics) .....	14

## Overview / Applications

---

The NBU-1312 discharge circuit is designed to simplify the development of solid-state laser systems. The module forms quasi-rectangular pulses on a flashlamp using energy stored in an external capacitors bank. The module includes an IGBT with its driver, protective circuits, simmer and trigger circuits, fast discharge resistors and control electronics.

NBU-1312 is the most powerful discharge circuit offered by OEM Tech. Due to the 4kW maximum average power and 1300V maximum output voltage its intended use is the driving of two flashlamp connected in series in high-power Nd:YAG and Alexandrite aesthetic laser systems.

It's important to emphasize that the NBU-1312 is not a stand-alone solution. It requires a capacitor charging power supply and a capacitor bank, as well as some minor parts and controls to operate properly.

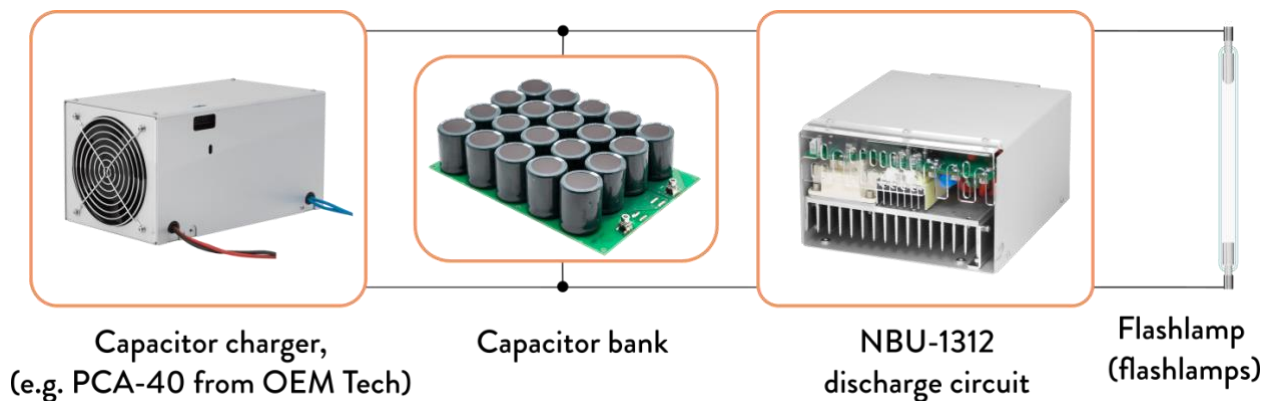

By default, the NBU-1312 includes capabilities both for series and external triggering (See *Triggering* section for details). Simplified as well as more complex modifications are available on request.

An important feature of the NBU-1312 is the clear and visible separation between the low-voltage and high-voltage parts. The 24V power input and all interface circuits (SIM and PWF) are separated from the high-voltage circuits by a 4 mm creepage distance and solid insulation to 2500 VAC test voltage.

## Cooling

---

The module is cooled with a built-in fan.  
No external cooling is required.

## Appearance

---



## Contents of delivery

---

By default, the delivery package contains the NBU-1312 module only.

The following standardized set of cables can be purchased optionally:

- Flashlamp connection cable – 2pcs (150cm each)
- Capacitor connection cable – 2pcs (30cm each)
- External trigger transformer connection cable with mounted 1:70 trigger transformer – 1pc (150cm)
- 24VDC cable – 1pc (50cm)
- SIM cable – 1pc (50cm)
- PWF cable – 1pc (50cm)

## Connections, signals, signal descriptions

---

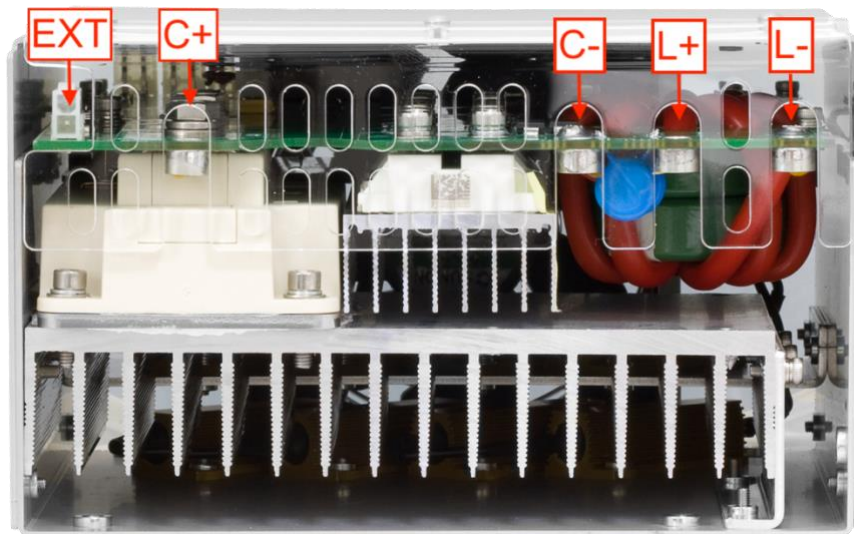

### CAPACITOR BANK CONNECTION: Two M5 terminals

C+ – to the capacitor bank positive

C– – to the capacitor bank negative

### FLASHLAMP CONNECTION: Two M5 terminals

L+ – to the flashlamp anode

L– – to the flashlamp cathode

### CAPACITOR CHARGER CONNECTION CONSIDERATIONS

**Note:** we recommend connecting the capacitor charging power supply not to C+/C– terminals, but directly to the capacitor bank.

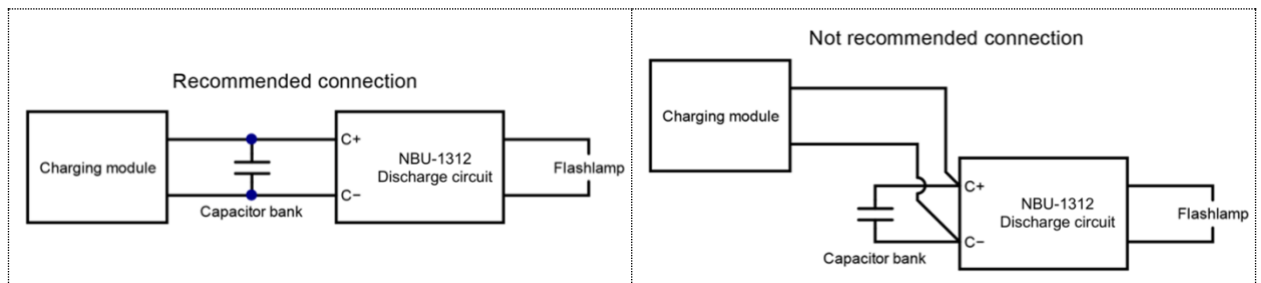

### EXT (TO THE TRIGGER TRANSFORMER): Molex 39-30-1020

By default, the NBU-1312 supports both series and external methods of triggering. To use the NBU-1312 for external triggering, a trigger transformer should be connected to the EXT connector. If the EXT

connector is left unconnected, the NBU-1312 automatically recognizes this and applies pulses of series triggering to L- flashlamp connection (see also *Triggering* section for details).



PIN (color)	DESIGNATION	DESCRIPTION
1 (-)	GND	Trigger transformer connection.
2 (-)	TRIGGER	Once a trigger transformer is connected, trigger pulses will be automatically applied to the EXT connector instead of L- flashlamp connector. Trigger pulse parameters: <ul style="list-style-type: none"> <li>• 350V by default, other on request</li> <li>• ~20mJ by default, other on request</li> </ul>

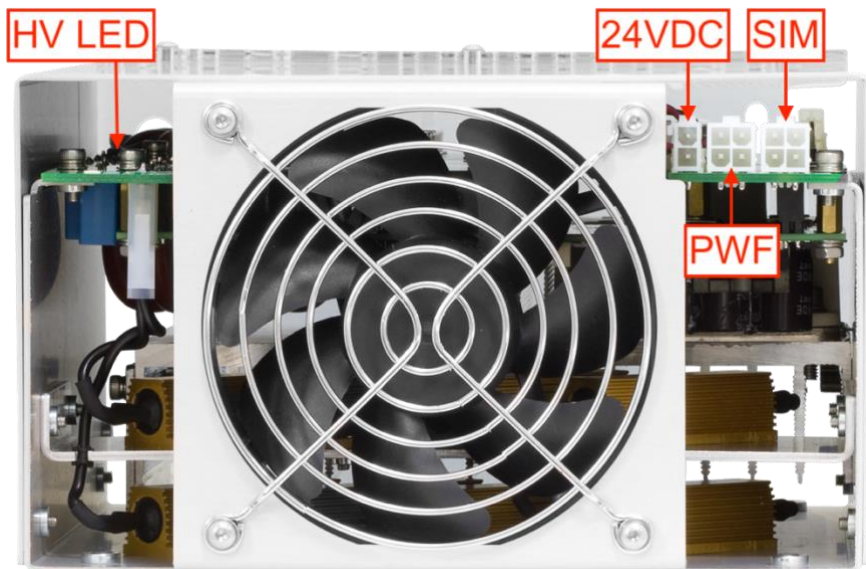

**24VDC (TO 24VDC POWER SUPPLY):** Molex 39-30-1020



PIN (color)	DESIGNATION	DESCRIPTION
1 (-)	+24VDC	Supply power to the control circuits of NBU-1312 as well as to the integrated simmer supply module <ul style="list-style-type: none"> <li>• Voltage: 24VDC</li> <li>• Current: 5A max. (up to 10A peak)</li> </ul>
2 (-)	+24VDC Return	Return of 24VDC power supply

**PWF (PULSE CONTROL):** Molex 39-30-1040



PIN (color)	DESIGNATION	DESCRIPTION
1 (-)	Discharge	When no voltage is applied to <i>PIN1</i> (or <i>PIN1</i> is unconnected), i.e. while <i>Discharge</i> is <i>ON</i> , the capacitor battery continuously discharges through internal 6kOhm 300W resistors. Be careful, while <i>Discharge</i> is <i>ON</i> the capacitor charging is prohibited and capacitor charging power supply must be disabled. While +5V voltage is applied to <i>PIN1</i> ( <i>Discharge</i> is <i>OFF</i> ) module can be operated in the regular way.
2 (-)	Not Connected	–
3 (-)	Pulse	Duration of +5V TTL pulse at <i>PIN3</i> completely defines IGBT-key open state time and, as a consequence, the flashlamp pulse duration
4 (-)	Interface Return	Return of <i>Pulse</i> and <i>Discharge</i> signals

### PWF CIRCUITS:

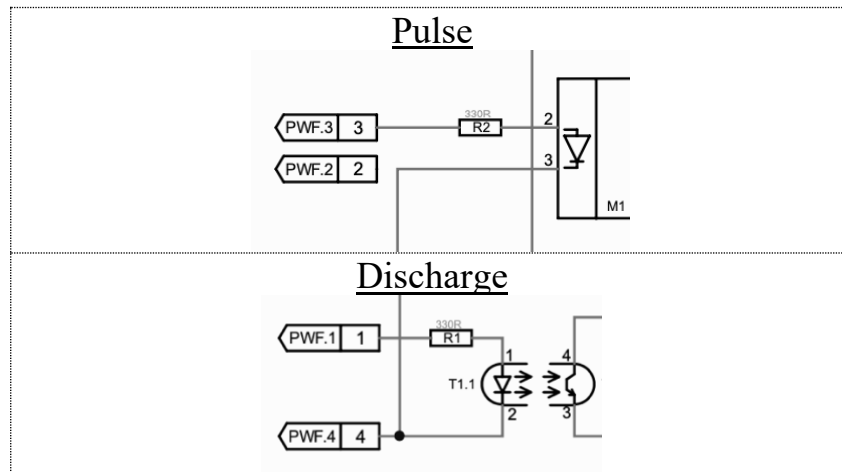

### SIM (SIMMER SUPPLY CONTROL): Molex 39-30-1040



PIN (color)	DESIGNATION	DESCRIPTION
1 (-)	Sensor Return	Return of the <i>Simmer Sensor</i> signal.
2 (-)	Simmer Sensor	The <i>Simmer Sensor</i> circuit is closed while simmer current flows through the flashlamp and is open while simmer current is absent.
3 (-)	Enable	Once a +5V voltage is applied to <i>PIN3</i> , the integrated simmer supply will attempt to strike and maintain a low-current discharge (simmer) in the flashlamp. If the flashlamp triggering fails, the simmer supply module will attempt to trigger it again at a few Hertz repetition rate. After a successful triggering, the simmer supply can support up to 500mA flashlamp current (400mA is a preset by default).

		Simmer will be maintained until 0V is applied to <i>PIN3</i> .
4 (-)	Enable Return	Return of the <i>Simmer Enable</i> signal.

**SIM CIRCUITS:**

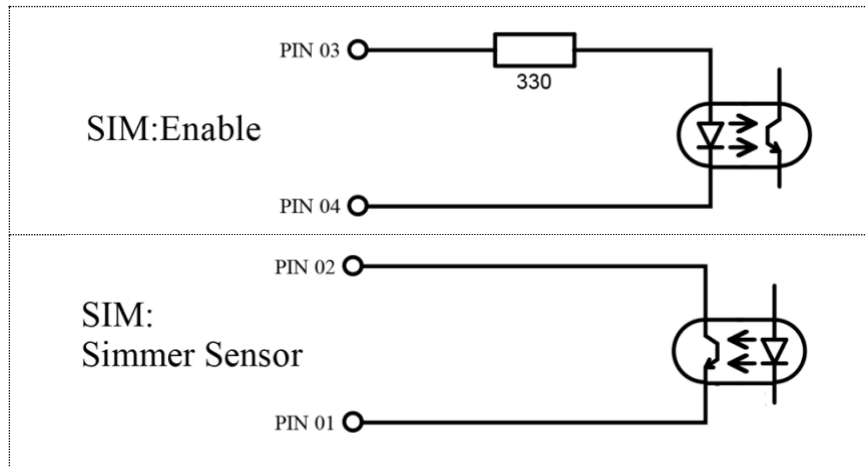

**LED:**

There is the warning LED indicating that NBU-1312 circuits are under high voltage.

HV LED (**red**) – is ON when NBU-1312 circuits are under high voltage

**GND: M4 THREADED TERMINAL**

The module should be grounded using this threaded terminal. Grounding should be carried out before the module is powered up.

## Safety

---

**Warning!** This equipment produces high voltages that can be very dangerous. Be careful around the device.

- During operation, all protective covers of the equipment must be securely fixed in place, and all electrical connections must be properly secured.
- The NBU-1312 discharge circuit is designed to be installed inside a properly grounded metal enclosure. It is the user's responsibility to ensure that personnel are prevented from accidentally contacting the NBU-1312, especially C+/C- and L+/L- connectors and cables.

**Accidental contact could be fatal!**

- After shutdown, do not handle the capacitive load until it has been fully discharged. Use an appropriate meter to verify complete discharge.
- Disconnect the module from the DC power source before making or changing any electrical or mechanical connections.
- **Don't remove protective covers!** There are no user-serviceable parts inside this equipment.

## Operations

---

A typical start-up sequence for the NBU-1312 is given below:

1. Connect your capacitor charging power supply, the +24V DC power supply, the capacitor bank and your flashlamp to the NBU-1312 module
2. Set +5V voltage on the PWF PIN1 to switch off the capacitor bank discharging

**Warning!** By default, the capacitor discharge is switched on.

Be careful and always switch off capacitor discharging before turning on your capacitor charging module.

Otherwise, it may lead to failure of discharge resistors used in the system.

3. *Disable* simmer supply (*PIN3* of *SIM* connector)
4. Apply +24V DC power to the module
5. *Enable* your capacitor charging power supply (charging module).  
As soon as charging module starts operation, capacitors are charged
6. *Enable* simmer supply (set +5V on *PIN3* of *SIM* connector)
7. Wait a few seconds for *Simmer Sensor*. If it fails, shut down your system
8. *Disable* your capacitor charging power supply before pulse

Note that PCP-series and PCA-series power supplies by OEM Tech are well-protected and it isn't obligatory to disable them. We recommend you do not disable PCP (PCA) at high on-off time ratio

9. Set +5V TTL pulse on *PIN3* of *PWF* connector. This pulse duration defines IGBT-key open state time and flashlamp pulse width.
10. *Enable* your power supply after the pulse
11. Repeat #8-#10

To power down the NBU-1312 and discharge the capacitor bank:

1. *Switch off* or *Disable* your capacitor charging power supply (important!)
2. *Disable* simmer supply
3. Set 0V on *PIN1* of *PWF* connector to switch on capacitor bank discharging. Wait for the complete discharge of the capacitors.

**Warning!** If the capacitor bank capacitance is enormously high, this might lead to the overheating of the discharge resistors used in the system.

4. Remove the +24V DC power from the module.

## Specifications

---

### ELECTRICAL

<b>+24VDC:</b>	
Voltage	+24V DC
Maximum current consumption	5A max., up to 10A peak
<b>PULSE PARAMETERS:</b>	
Max. voltage	1300V ( <i>up to 1500V on request</i> )
Max. discharge current ( <a href="#">depends on flashlamp impedance K0</a> )	1000A for pulse width < 1ms 500A for pulse width > 1ms ( <i>other on request</i> )
Max. average power	4000W ( <i>other on request</i> )
Min. pulse width, max. pulse width	Accordingly to <i>PWF:Pulse</i> signal
Max. rep. rate	50Hz ( <i>up to 200Hz on request</i> )
<b>RECOMMENDED WIRES:</b>	
For capacitor bank connections	FLEXI-2V or similar (>1300V rated voltage, >6mm <sup>2</sup> cross-section), short length (30cm recommended)
For flashlamp connections	For external triggering – FLEXI-2V or similar (>1300V rated voltage, >6mm <sup>2</sup> cross-section) For series triggering additional insulation (e.g. with silicone tubing) or spacing (e.g. with spiral bundle hose) of L– wire is required
<b>SIMMER PARAMETERS:</b>	
Simmer current	400mA ( <i>200-500mA on request</i> )
Max. output voltage	500V
Max. output power	100W
Open circuit voltage	1500V
<b>FLASHLAMP TRIGGERING PARAMETERS:</b>	
Trigger pulse width	~1us
Restrike rate	A few Hertz (automatically adjusted)
<b>EXTERNAL TRIGGERING:</b>	
Pulse energy / trigger voltage	~20mJ / 350V positive to the EXT connector ( <i>other on request</i> )

Trigger transformer	External transformer (purchased separately) Recommended p/n <i>ZS1324-24V LUL1(H)</i> by Excelitas Technologies (Digikey p/n <i>ZS1324- 24VLUL1(H)-ND</i> )
<b>SERIES TRIGGERING:</b>	
Pulse energy / trigger voltage	~160mJ / 10kV negative to L– ( <i>other on request</i> )
Trigger transformer	Integrated transformer
<b>Cooling</b>	Forced air cooling with built-in fan
<b>Safety</b>	1 MOOP/MOPP between high-voltage and low-voltage parts (4mm creepages / 2500VAC HiPot)
	Fast discharge of the capacitor bank through 6kOhm/1300V/300W embedded discharge resistors
<b>Protections</b>	From overheating of internal components
<b>ENVIRONMENT:</b>	
Operation temperature	0 ... +40 °C
Storage temperature	-20 ... +60 °C
Humidity	<90%, non-condensing

### MECHANICAL

<b>Size (LxWxH)</b>	Approx. 214x177x106mm (see also the dimensional drawing below)
<b>Weight</b>	Approx. 3.0kg (w/o cables)

## Dimensional drawing

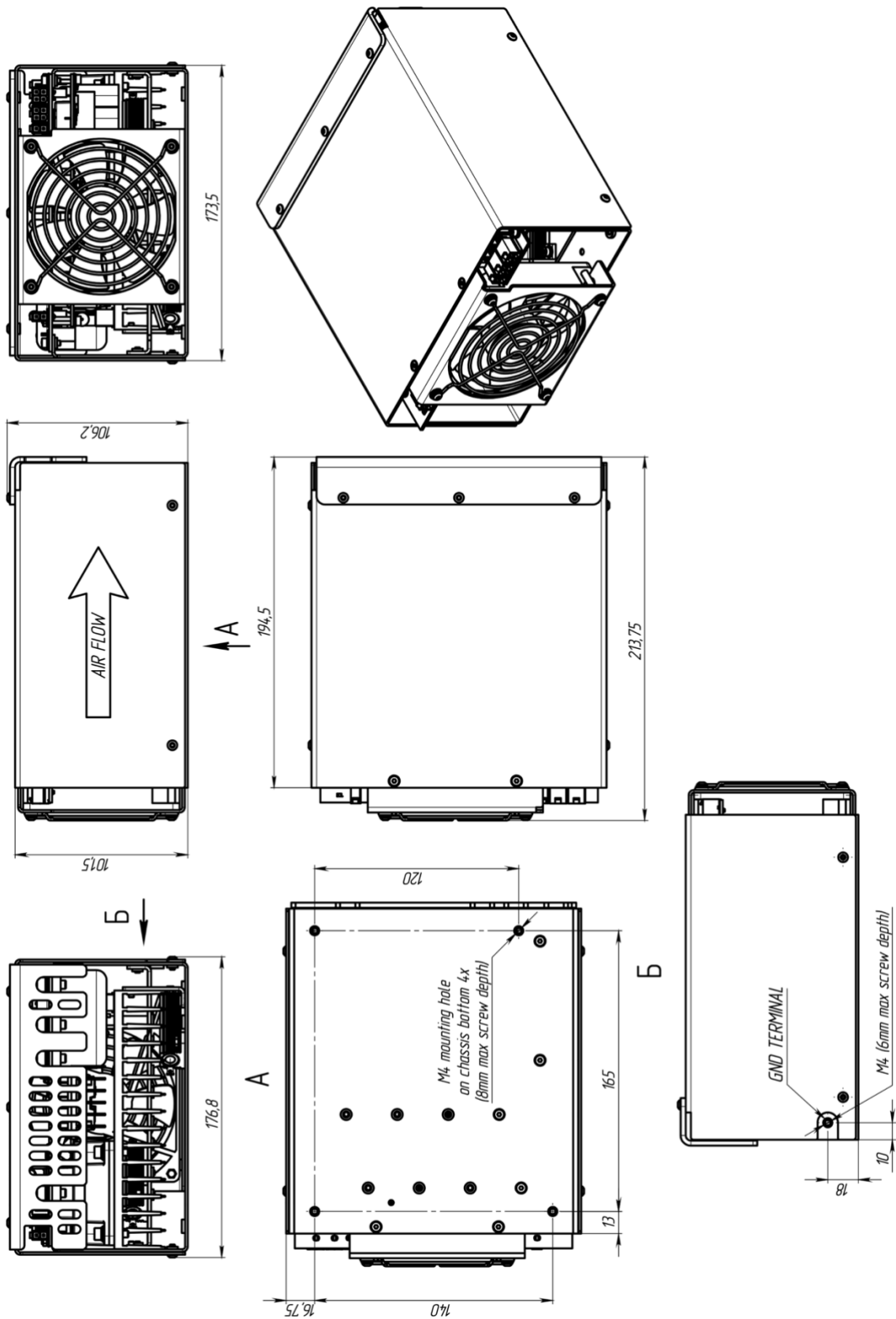

## How to order?

---

By default, there is the only one standard part number, namely the NBU-1312.

The following options are available on request:

- Integrated current sensor
- Digital RS-232 / RS-485 interface
- Modified cables and connectors
- Modified simmer and / or trigger parameters

## Triggering (series triggering, external triggering, triggering basics)

---

By default, the NBU-1312 supports both series and external methods of triggering.

To use the NBU-1312 for external triggering, a trigger transformer should be connected to the EXT connector.

Default parameters for external triggering are (others on request):

- 350V voltage (applied to the EXT connector)
- ~20mJ energy
- Recommended transformer (sold separately) – 1:70 e.g. *ZS1324-24V LUL1(H)* by Excelitas Technologies (Digikey p/n *ZS1324-24VLUL1(H)-ND*)

If the EXT connector is left unconnected, the NBU-1312 automatically recognizes this and applies series triggering to the flashlamp.

Default parameters for series triggering are (others on request):

- 10kV voltage (applied to L-)
- ~160mJ energy